

The 5th International Conference on Industrial, Mechanical, Electrical, and Chemical Engineering 2019 (ICIMECE 2019)

Surakarta, Indonesia • 17–18 September 2019

Editors • Wahyudi Sutopo, Miftahul Anwar, Muhammad Hamka Ibrahim,
Hari Maghfiroh, Chico Hermanu Brilianto Aribowo,
Sutrisno Ibrahim and Muhammad Hisjam



INTERNATIONAL ADVISORY BOARD

INTERNATIONAL ADVISORY BOARD

Prof. Josaphat Tetuko Sri Sumantyo, Ph.D. Scopus ID : 7801490558 | H-Index : 13

Chiba University, Japan

Assoc. Prof. Dr. Nafarizal Bin Nayan, Scopus ID : 8881976900 | H-Index : 10

Khon Kaen University, Thailand

Prof. Nonglak Meethong, Ph.D Scopus ID : 13410697800 | H-Index : 1

Khon Kaen University, Thailand

Assoc. Prof. Chao-Min Wu, Scopus ID : 56132665300 | H-Index : 3

National Central University, Taiwan

STEERING COMMITTEE

Dr. Techn. Ir. Sholihin As'ad, M.T. Scopus ID : 53864697200 | H-Index : 2

Universitas Sebelas Maret, Indonesia

Dody Ariawan, S.T., M.T., Ph.D. Scopus ID : 56352104600 | H-Index : 4

Universitas Sebelas Maret, Indonesia

Feri Adriyanto, Ph.D. Scopus ID : 6505505624 | H-Index : 6

Universitas Sebelas Maret, Indonesia

INTERNATIONAL TECHNICAL PROGRAM

Associate Professor Dr. Ahad Ali, Scopus ID : 24802068000 | H-Index : 8

Industrial Engineering Program, Lawrence Technological University, Michigan, USA

Prof. Ir. Dr. Ing. Eko Supriyanto, Scopus ID : 57194261987 | H-Index : 19

Universiti Teknologi Malaysia, Malaysia

Ir. Tumiran, M. Eng., Ph.D, Scopus ID : 24279155800 | H-Index : 6

Indonesian National Energy Council

Prof. Dr. Nurul Taufiqu Rochman, M.Eng, Ph.D, Scopus ID : 6602424296 | H-Index : 5

Research Center for Physics, Indonesian Institute of Sciences, Indonesia

Assoc. Prof. Ir. Dr. Edwin Jong Nyon Tchan,

Curtin University Malaysia

Dr. Kiwi Aliwarga

CEO and Founder of UMG, Vietnam

Dr. Robert de Souza PhD, MSc, BSc Hons, Scopus ID : 24354814400 | H-Index : 15

National University of Singapore

Conference Chair

Dr. Wahyudi Sutopo, S.T.,M.Si, Scopus ID : 420625336300 | H-Index : 6
Universitas Sebelas Maret, Indonesia

Conference Co-Chair

Dr. Miftahul Anwar S.Si., M.Eng., Scopus ID : 7202759490 | H-Index : 6
Universitas Sebelas Maret, Indonesia
Dr. Muh. Hisjam, S.T.P.,M.T., Scopus ID : 54947278700 | H-Index : 5
Universitas Sebelas Maret, Indonesia

SECRETARY

Agus Ramelan, S.Pd., M.T., Scopus ID : 57203956839 | H-Index : 1
Universitas Sebelas Maret, Indonesia

TREASURE

Chico Hermanu Brillianto Apribowo S.T., M.Eng., Scopus ID : 57194242379 | H-Index : 1
Universitas Sebelas Maret, Indonesia
Subuh Pramono S.T., M.T., Scopus ID : 35796215300 | H-Index : 4
Universitas Sebelas Maret, Indonesia

TECHNICAL PROGRAM CHAIR

Hari Maghfiroh S.T., M.Eng., Scopus ID : 56103976500 | H-Index : 2
Universitas Sebelas Maret, Indonesia
Dr. Ari Diana Susanti, S.T., M.T., Scopus ID : 57194505773 | H-Index : 1
Universitas Sebelas Maret, Indonesia

JOURNAL AND PUBLICATION CHAIR

Muhammad Hamka Ibrahim ST., M.Eng. , Scopus ID : 55602892900 | H-Index : 1
Universitas Sebelas Maret, Indonesia

CORPORATE PARTNERSHIP CHAIR

Fakhrina Fahma, S.TP., M.T. , Scopus ID : 57190370778 | H-Index : 3
Universitas Sebelas Maret, Indonesia

ACCOMODATION

Joko Slamet Saputro, S.Pd., M.T., Universitas Sebelas Maret, Indonesia

CONSUMPTION

Inayati, S.T., M.T., Ph.D., Scopus ID : 36709913700 | H-Index : 1
Universitas Sebelas Maret, Indonesia
Rahmaniyah Dwi Astuti, S.T.,M.T., Scopus ID : 56180646700 | H-Index : 1
Universitas Sebelas Maret, Indonesia

TRANSPORTATION

Jaka Sulistya Budi, S.T.
Universitas Sebelas Maret, Indonesia

WEBMASTER AND PUBLICITY

Sutrisno, S.T., M.Sc, Ph.D
Universitas Sebelas Maret, Indonesia

TABLE OF CONTENT

Preface: The 5th International Conference on Industrial, Mechanical Electrical, and Chemical Engineering 2019 (ICIMECE 2019)

AIP Conference Proceedings 2217, 010001 (2020); <https://doi.org/10.1063/12.0000222>

Detection of forest fire used multi sensors system for peatland area in Riau Province

Evizal Abdul Kadir, Sri Listia Rosa and Rizdqi Akbar Ramadhan

AIP Conference Proceedings 2217, 020003 (2020); <https://doi.org/10.1063/5.0000493>

Drilling of AISI 316L stainless steel: Effect of coolant condition on surface roughness and tool wear

Ahmad Zubair Sultan, Safian Sharif and Denni Kurniawan

AIP Conference Proceedings 2217, 020004 (2020); <https://doi.org/10.1063/5.0000548>

The effect UV-B mutation on biodiesel from microalgae *Botryococcus braunii* using esterification, transesterification and combination of esterification-transesterification

Anggia Putri Ramadhani, Muhammad Hafizh Prashantyo, Thea Prastiwi Soedarmodjo and Arief Widjaja

AIP Conference Proceedings 2217, 030021 (2020); <https://doi.org/10.1063/5.0000554>

An experimental study of a car maintenance workshop layout optimization

Agung Premono, Matheus Victor and Himawan Hadi Sutrisno

AIP Conference Proceedings 2217, 030008 (2020); <https://doi.org/10.1063/5.0000585>

Bontang LNG plant operational strategy to manage ethane refrigerant inventory during low NGL extraction

Rendra Prasetyo and Putri Cahyaning Prabandoro

AIP Conference Proceedings 2217, 030006 (2020); <https://doi.org/10.1063/5.0000597>

Analysis of working posture on musculoskeletal disorders of vocational garment student's in garment assembly operations practice

Irham Aribowo, Bambang Suhardi and Eko Pujiyanto

AIP Conference Proceedings 2217, 030016 (2020); <https://doi.org/10.1063/5.0000602>

Robot control systems using bio-potential signals

Minoru Sasaki, Kojiro Matsushita, Muhammad Ilhamdi Rusyidi, Pringgo Widyo Laksono, Joseph Muquro, Muhammad Syaiful Amri bin Suhaimi and Waweru Njeri

AIP Conference Proceedings 2217, 020008 (2020); <https://doi.org/10.1063/5.0000624>

Classification of Indonesian coffee types with deep learning

Alfan Rivalto, Pranowo and Albertus Joko Santoso

AIP Conference Proceedings 2217, 030014 (2020); <https://doi.org/10.1063/5.0000678>

The effects of carbon cap limitations on inventory and multimodal transportation

Thina Ardliana, I. Nyoman Pujawan and Nurhadi Siswanto

AIP Conference Proceedings **2217**, 030019 (2020); <https://doi.org/10.1063/5.0000697>

Mechanical properties of films from carboxy methyl glucomannan and carrageenan with glycerol as plasticizer

Fadilah, Ari Diana Susanti, Sperisa Distantina, Dea Putri Purnamasari and Jihan Fahrizal Ahmad

AIP Conference Proceedings **2217**, 030022 (2020); <https://doi.org/10.1063/5.0000842>

A framework of stand up motorized wheelchair as universal design product to help mobility of the motoric disabled people

B. Bambang Sulistiyawan, Susy Susmartini and Lobes Herdiman

AIP Conference Proceedings **2217**, 030026 (2020); <https://doi.org/10.1063/5.0001084>

Performance comparison of fleet management system using IoT node device based on MQTT and HTTP protocol

Harry Kasuma Aliwarga, Alwy Herfian Satriatama and Bruno Fandi Adi Pratama

AIP Conference Proceedings **2217**, 020009 (2020); <https://doi.org/10.1063/5.0003076>

Interface damage mechanics in fiber reinforced plastic composite – A review

Bentang Arief Budiman and Putri Nur Halimah

AIP Conference Proceedings **2217**, 020002 (2020); <https://doi.org/10.1063/5.0000808>

An application of support vector machine to detect anomalies in time series data

Yoga S. Satriawan and Joko Slamet Saputro

AIP Conference Proceedings **2217**, 030201 (2020); <https://doi.org/10.1063/5.0000659>

Experimental investigation of blades number of savonius water turbine on performance characteristic

Dwiseno Wihadi and Stefan Mardikus

AIP Conference Proceedings **2217**, 030165 (2020); <https://doi.org/10.1063/5.0001063>

Photodegradation of batik waste with graphitic carbon nitride using UV-BLB

Bagas Cahyadi, Leony Inatsan Pertiwi, Queenta Perdanita Putri and Anatta Wahyu Budiman

AIP Conference Proceedings **2217**, 030200 (2020); <https://doi.org/10.1063/5.0000665>

Performance comparison of VPPM visible light communication demodulator using analog to digital converter and analog comparator sampling

Muhammad Hamka Ibrahim, Miftahuddin Irfani, Annisa Hanifa and Subuh Pramono

AIP Conference Proceedings **2217**, 030126 (2020); <https://doi.org/10.1063/5.0000591>

Numerical solution of Darcy-Brinkman-Forchheimer equation for forced-convective fluid flow through porous medium using DMLPG method

Pranowo and Agung Tri Wijayanta

AIP Conference Proceedings 2217, 030171 (2020); <https://doi.org/10.1063/5.0000586>
Sentiment analysis of Indonesian presidential election 2019 on the twitter with lexicon-based and support vector machine (SVM)

Fredericus Dwi Nugraha Putra, Pranowo and Budiyanto Setyohadi

AIP Conference Proceedings 2217, 030136 (2020); <https://doi.org/10.1063/5.0000631>

Synthesis of Co/Ni – Hydroxyapatite by electrochemical method

Adrian Nur, Anatta Budiman, Arif Jumari, Fauziatul Fajaroh, Nazriati, M. Novalianto Sangadji and Hanifah Ayu Pratiwi

AIP Conference Proceedings 2217, 030015 (2020); <https://doi.org/10.1063/5.0000640>

Application of titanium doped g-C₃N₄ for the degradation of toxic dyes in textiles wastewater

Anatta Wahyu Budiman, Bregas S. T. Sembodo, Ahmad Alviansyah and Irma B. S. Putri

AIP Conference Proceedings 2217, 030127 (2020); <https://doi.org/10.1063/5.0000663>

Production of LiNi_{0.6}Mn_{0.2}Co_{0.2}.2O₂ via fast oxalate precipitation for Li-ion

Arif Jumari, Khikmah Nur Rikhy Stulasti, Refarmita Nur Halimah, Agus Purwanto, Luthfiatul Azizah Aini and Rahmawati Mintarsih

AIP Conference Proceedings 2217, 030011 (2020); <https://doi.org/10.1063/5.0000646>

Parallel simulation of pattern formation in a reaction-diffusion system of FitzHugh-Nagumo using GPU CUDA

Alfredo Gormantara and Pranowo

AIP Conference Proceedings 2217, 030134 (2020); <https://doi.org/10.1063/5.0000667>

The influence of magnesium oxide and montmorillonite on the flame retardant and flexural strength of fiber glass-unsaturated polyester composites

Sahid Bayu Setiajit, Kuncoro Diharjo and Wijang Wisnu Raharjo

AIP Conference Proceedings 2217, 030150 (2020); <https://doi.org/10.1063/5.0000723>

Ergonomic improvement in a manufacturing company

Tuan Ahmad Farhan Hakimi, Syed Ahmad Helmi, Muhammad Hisjam and Ahad Ali

AIP Conference Proceedings 2217, 030199 (2020); <https://doi.org/10.1063/5.0000729>

Effect of environment on the defects of welded aluminum AA 1100

Rafael Simanjuntak, Nurul Muhyat, Aditya Rio Prabowo, Y. C. N. Saputro and Triyono

AIP Conference Proceedings 2217, 030135 (2020); <https://doi.org/10.1063/5.0000811>

Savonius turbine performance with slotted blades

Catur Harsito, Dominicus Danardono Dwi Prija Tjahjana and Budi Kristiawan

AIP Conference Proceedings 2217, 030071 (2020); <https://doi.org/10.1063/5.0000797>

Design and development of PC-based smart programmable power supply for battery charging system

Muhammad Hamka Ibrahim, Rizal Abdulrozaq Rosadi, Agus Ramelan and Chico Hermanu Brillianto Apribowo

AIP Conference Proceedings 2217, 030131 (2020); <https://doi.org/10.1063/5.0000628>
Performance comparison in simulation of Mandelbrot set fractals using Numba

Gilbert Gutabaga Hungilo, Gahizi Emmanuel and Pranowo

AIP Conference Proceedings 2217, 030007 (2020); <https://doi.org/10.1063/5.0000636>

Design and implementation of autonomous solar powered iot farm monitoring system using MQTT over cellular network

Muhammad Hamka Ibrahim, Chico Hermanu Brillianto Apribowo, Fahmi Ismail, Bima Damar Jati, Sony Adyatama, Attar Al Mufashal Rasyid and Bima Tri Prasetya

AIP Conference Proceedings 2217, 030203 (2020); <https://doi.org/10.1063/5.0000800>

Biodiesel production from waste cooking oil by using zirconia catalyst

Khoirun Nisa, Diah Ayu Almaas Salwa, Alfi Hasanah and Widayat

AIP Conference Proceedings 2217, 030120 (2020); <https://doi.org/10.1063/5.0000912>

Slotted blade effect on Savonius wind rotor performance

Agung Dwi Nugroho, Dominicus Danardono Dwi Prija Tjahjana and Budi Kristiawan

AIP Conference Proceedings 2217, 030102 (2020); <https://doi.org/10.1063/5.0000891>

Dye sensitized solar cell (DSSC) with immersion time variation of working electrode on the dye of C₄ plant chlorophyll of corn leaves (*Zea mays* L.)

R. Anggraini, F. Nurosyid and T. Kusumaningsih

AIP Conference Proceedings 2217, 030084 (2020); <https://doi.org/10.1063/5.0000600>

Performance analysis of MMSE based interference suppression in MU MIMO system

Subuh Pramono, Budi Basuki Subagio, Eddy Triyono, Agus Ramelan, Chico Hermanu Brillianto Apribowo and Muhammad Hamka Ibrahim

AIP Conference Proceedings 2217, 030115 (2020); <https://doi.org/10.1063/5.0000736>

Application of quality function deployment for diversification of souvenirs of ATBM woven fabrics for foreign tourist needs (case study: Sragen Regency)

Navy Salem, Eko Liquidanu, I. Wayan Suletra and Murman Budijanto

AIP Conference Proceedings 2217, 030077 (2020); <https://doi.org/10.1063/5.0000746>

The design of automatic syringe shaker as the media supporting method of dissolved gas analysis (DGA) transformer oil

Ratih Rachmatika, Augustinus Sujono and Chico Hermanu Brillianto Apribowo

AIP Conference Proceedings 2217, 030132 (2020); <https://doi.org/10.1063/5.0000812>

Experimental method for improving efficiency on photovoltaic cell with using floating installation method

Chico Hermanu Brillianto Apribowo, Abyan Habibie, Zainal Arifin and Feri Adriyanto

AIP Conference Proceedings 2217, 030190 (2020); <https://doi.org/10.1063/5.0000827>
Investigation on multi-channel types of primary reformer catalyst using computational fluid dynamic (CFD)

Ari Diana Susanti and Yazid Bindar

AIP Conference Proceedings 2217, 030151 (2020); <https://doi.org/10.1063/5.0000756>
Current-voltage monitoring of plasma arc discharge submerged in water for nanoparticles fabrication

Lia Anjarwati, Miftahul Anwar, Yan Mahardhika, Ramanda Fadhillah, Chico Hermanu Brillianto Aribowo, Teguh Endah Saraswati and Yuana Ayub

AIP Conference Proceedings 2217, 030185 (2020); <https://doi.org/10.1063/5.0000978>

ICIMECE 2019

International Conference on Industrial, Mechanical, Electrical and Chemical
Engineering

Manuscript is now published online
For the details check here

Conference Program

Day 1, Tuesday, September 17, 2019

Time	Program			
08.00 - 09.00	Registration			
09.00 - 09.45	Opening Ceremony			
09.45 - 10.00	Coffee Break			
10.00 - 12.00	Plenary Session I Moderator: Dr. Eng. Aditya Rio Prabowo, S.T., M.T., M.Eng. Prof. Ir. Dr.-Ing. Eko Supriyanto Prof. Dr. Nurul Taufiqu Rochman, M.Eng, Ph.D Harry Kasuma (Kiwi) Aliwarga Prof. Minoru Sasaki			
12.00 - 13.00	Lunch Break			
13.00 - 15.10	Parallel Session I			
	Emerald (EE)		Opal (ME)	
	Moderator : Sutrisno, ST., M.Sc. PhD.		Moderator : Dharu Feby Smaradhana, ST., M.Sc.	
13.00 - 13.20	Invited - 1 Dr. Eng Budi Prawara		13.00 - 13.20	Invited - 2 Assoc. Prof. Kojiro Matsushita
13.20 - 13.40	Invited - 6 Sarjiya, S.T., M.T., Ph.D		13.20 - 13.40	Invited - 7 Dr. Denni Kurniawan
13.40 - 14.10	EE-010, EE-231 EE-246		13.40 - 14.10	ME-007, ME-084 ME-109
14.10 - 14.40	EE-139, EE-142 EE-157		14.10 - 14.40	ME-196, ME-229 ME-248



13.00 - 15.10	14.40	EE-198, EE-283	14.40	ME-284, ME-048
	-		-	
	15.10	EE-285	15.10	ME-083
	Sapphire (CE)		Topaz (IE)	
	Moderator : Mujtahid Kaavessina, S.T., M.T., PhD.		Moderator : Yusuf Priyandari, S.T.,M.T.	
	13.00	Invited - 3	13.00	Invited - 4
	-	Assoc. Prof. Dr.	-	Dr. Evizal Abdul
	13.20	Agus Saptoro	13.20	Kadir, S.T, M.Eng.
	13.20	Invited - 8	13.20	Invited - 9
	-	Prof. Shigeyuki	-	Dr. Eng. Bentang
	13.40	Uemiya	13.50	Arief Budiman
	13.40	CE-004, CE-052	13.50	IE-032, IE-033
	-		-	
	14.10	CE-056	14.20	IE-053
	14.10	CE-127, CE-136	14.20	IE-063, IE-085
-		-		
14.40	CE-193	14.50	IE-090	
14.40	CE-014, CE-086	14.50	IE-114, IE-115	
-		-		
15.10	CE-202	15.20	IE-116	
Crystal (IE2)				
Moderator : Yuniaristanto, S.T.,M.T.				
13.00	Invited - 5			
-	Budi Hartono,			
13.20	ST,			
	MPM, Ph.D			
13.20	Invited - 10			
-	Dr. Jafri Bin			
13.40	Mohd			
	Rohani			



13.00 - 15.10	13.40	IE-141, IE-154		
	-			
	14.10	IE-222		
	14.10	IE-226, IE-233		
	-			
	14.40	IE-234		
	14.40	IE-242, IE-245		
	-			
	15.10	IE-011		
15.10 - 15.25	Coffee Break			
15.25- 16.55	Parallel Session II			
	Emerald (EE)		Opal (ME)	
	Moderator : Sutrisno, ST., M.Sc. PhD.		Moderator : Dharu Feby Smaradhana, ST., M.Sc.	
	15.25	CS-002, CS-018, CS-174	15.25	ME-134, ME-148 ME-149
	-		-	
	15.55	CS-016, CS-022	15.55	ME-156, ME-203
	-	CS-023	-	ME-218
	16.25	CS-024, CS-167	16.25	ME-221, ME-250
	-	CS-181	-	ME-261
	16.55		16.55	
	Sapphire (CE)		Topaz (IE)	
	Moderator : Mujtahid Kaavessina, S.T., M.T., PhD.		Moderator : Yusuf Priyandari, S.T.,M.T.	
	15.25	CE-270, CE-279 CE-027	15.25	IE-019, IE-029 IE-042
	-		-	
	15.55	CE-036, CE-037	15.55	IE-075, IE-082
	-	CE-054	-	IE-088
16.25	CE-192, CE-223	16.25	IE-091, IE-103	
-	CE-230	-	IE-104	
16.55		16.55		



15.25 – 16.55	Crystal (IE2)	
	Moderator : Yuniaristanto, S.T.,M.T.	
	15.25 -	IE-108, IE-110
	15.55	IE-117
	15.55 -	IE-119, IE-123
	16.25	IE-124
16.25 -	IE-133, IE-135	
16.55	IE-	
19.00 - 21.00	Gala Dinner	

Day 2, Wednesday, September 18, 2019

Time	Program			
08.00 - 09.00	Registration			
09.00 - 10.20	Plenary Session II Moderator: Dr. Muh. Hisjam, S.T.P., M.T. Assoc. Prof. Ir. Dr. Edwin Jong Nyon Tchan Dr. Robert de Souza PhD, MSc, BSc Hons			
10.20 - 10.35	Coffee Break			
10.35 - 11.55	Parallel Session I			
	Emerald (EE)		Opal (ME)	
	Moderator : Joko Slamet Saputro, S.Pd., M.T.		Moderator : Fitriani Imaduddin, S.T., M.Sc., Ph.D.	
	10.35 -	Invited - 11 Dr. Ratna Purwaningsih, S.T., M.T.	10.35 -	Invited - 12 Dr. Fethma M Nor
	10.55	EE-076, EE-243	10.55	ME-140, ME-017
	11.25	EE-280	11.25	ME-107



	11.25 - 11.55	CS-210, CS-244 CS-216	11.25 - 11.55	ME-143, ME-147 ME-195
10.35 – 11.55	Sapphire (CE)		Topaz (IE)	
	Moderator : Anatta Wahyu Budiman, S.T., Ph.D.		Moderator : Dr. Eko Pujiyanto, S.Si., M.T.	
	10.35 - 10.55	Invited -13 Dr. Norizah Bt Hj Redzuan, Ph.D.	10.35 - 11.05	IE-080, IE-093 IE-100
	10.55 - 11.25	CE-247, CE-264	11.05 - 11.35	IE-152, IE-170 IE-171
	11.25 - 11.55	OTS	11.35 - 12.00	IE-189, IE-190 IE-197
	Crystal (IE2)			
	Moderator : Wakhid Ahmad Jauhari, S.T., M.T.			
	10.35 - 11.05	IE-186, IE-241 IE-263		
	11.05 - 11.35	IE-262, IE-138 IE-160		
	11.35 - 12.00	IE-163, IE-164 IE-175		
	11.55 - 13.00	Lunch		



13.00 - 17.00		Parallel Session I			
		Emerald (EE)		Opal (ME)	
		Moderator : Joko Slamet Saputro, S.Pd., M.T.		Moderator : Fitriani Imaduddin, S.T., M.Sc., Ph.D.	
13.00	CS-261, CS-012	13.00	ME-211, ME-267	-	
-		-		-	
13.30	CS-212	13.30	ME-268		
13.30	EE-009, EE-057	13.30	OTS		
-		-			
14.00	EE-062	14.00			
14.00	EE-066, EE-081	14.00	OTS		
-		-			
14.30	CS-227	14.30			
14.30	OTS	14.30	OTS		
-		-			
15.00		15.00			
15.00	OTS	15.00	OTS		
-		-			
15.30		15.30			
16.00	OTS	16.00	OTS		
-		-			
16.30		16.30			
16.30	OTS	16.30	OTS		
-		-			
17.00		17.00			
		Sapphire (CE)		Topaz (IE)	
		Moderator : Anatta Wahyu Budiman, S.T., Ph.D.		Moderator : Dr. Eko Pujiyanto, S.Si., M.T.	
13.00		13.00			
-		-			
13.30	OTS	13.30	IE-235, IE-253		
13.30		13.30	IE-256		
13.30	OTS	13.30	IE-281, IE-045		
-		-			
14.00		14.00	IE-064		



	14.00 - 14.30	OTS	14.00 - 14.30	IE-065, IE-209 IE-275	
13.00 – 17.00	14.30 - 15.00	OTS	14.30 - 15.00	IE-278	
	15.00 - 15.30	OTS	15.00 - 15.30	OTS	
	16.00 - 16.30	OTS	16.00 - 16.30	OTS	
	16.30 - 17.00	OTS	16.30 - 17.00	OTS	
	13.00 - 13.30	OTS	13.00 - 13.30	OTS	
	Crystal (IE2)				
	Moderator : Wakhid Ahmad Jauhari, S.T., M.T.				
	13.00 - 13.30	IE-046, IE-055 IE-070			
	13.30 - 14.00	IE-073, IE-074 IE-079			
	14.00 - 14.30	IE-126, IE-191 IE-205			
	14.30 - 15.00	OTS			
	15.00 - 15.30	OTS			



13.00 – 17.00	15.30	OTS
	-	
	16.00	OTS
	16.00	
	-	
	16.30	OTS
16.30		
-		
17.00		

*OTS : On The Spot Registration



Detection of Forest Fire Used Multi Sensors System for Peatland Area in Riau Province

Evizal Abdul Kadir^{1,a)} Sri Listia Rosa^{2,b)} Rizdqi Akbar Ramadhan^{3,c)}

¹²³*Department of Informatics Engineering, Faculty of Engineering, Universitas Islam Riau
Jl. Kaharuddin Nasution No.113 Marpoyan, Pekanbaru, Riau, Indonesia 28284*

^{a)} *evizal@eng.uir.ac.id*

^{b)} *srlistiarosa@eng.uir.ac.id*

^{c)} *rizdqiramadhan@eng.uir.ac.id*

Abstract. Forest fire is one of the major issue in Indonesia, especially in Riau province because forest fire very dangerous impact on environments and people because of haze and carbon emits from the fire. The most technology to detect fire hotspot so far is using satellite image then process to determine number hotspot and the location. Some weakness in this technology which is in bad weather or cloudy then satellite system cannot penetrate. In this research propose ground sensor system which is using multi sensors related to the parameters of fire, especially fire in peatland area with a special case of fire. Common parameter of the fire such as temperature, smoke, haze, and carbon dioxide applied in this system then measure the indicator used the special sensor. Results of every sensor analyze by apply to intelligent computer programming and algorithm to determine fire hotspot and location. Results show based on integrated multiple sensors, determination of fire hotspot location and intensity more accurate comparison to the use of single sensor determination. Data collected from every sensor keep in an internal database and in some of the period generate a graph for a report as well as for record.

Keywords—Forest fire, Multi sensor, Peatland, WSNs

Introduction

Forest fires in Indonesia seem to become a regional and global disaster, the fire impact spread to neighboring countries and gases combustion emitted into the atmosphere (Co₂) has the potential to cause global warming. Initial forest fires were thought to occur naturally because of dryland and hot environmental, but it is likely that humans have a role to play in starting fires in the last decade, hunting and opening up patches of agriculture in the forest. Although fires have been a feature of forests in Indonesia for hundreds of years, fires that occurred initially must have been smaller and more dispersed in terms of frequency and time than in the past two decades, these initial fires were not a cause of significant deforestation.

The first major fire which was the result of a combination of improper forest management and the El Nino climate phenomenon destroyed millions of hectare, of which a few millions hectare were tropical forests (Schindler et al. 1989). According to the National Development Planning Agency (BAPPENAS) together with the Asian Development Bank (ADB) estimated 9.75 million hectares of the forest fire. Furthermore, Indonesian forest fires continue every year though area burned and losses it is relatively small and generally not well documented. Data from the Directorate

General of Forest Protection and Nature Conservation shows that forest fires that occur every year from 2000 to 2002 recorded ranging from 42 thousand to 2.6 million hectares. One of the impacts that occurred due to forest fires the presence of fog. The haze caused forest fires in Riau province, Indonesia has been troubling and bring disease to residents. A number of hospitals, especially clinic in the suburban and urban area are flooded with patients Acute Respiratory Tract Infection (ARI), especially children and elderly people physical endurance is very weak and must breathe the air that is not already healthy due to smoke from forest fires. The haze itself had struck almost all regions in Riau since mid of January, along with the rampant forest fires. The haze is felt at days and night with hot temperatures. The haze gradually fades in the morning along with sunrise and this keeps repeating every day since the forest fire occurred.

The impact of fires that are felt by humans in the form of economic losses is a benefit from forest potentials such as forest trees that are commonly used by humans to meet their needs for building materials, food ingredients and medicines, and animals to meet the needs for animal protein and recreation. Other disadvantages include ecological losses, namely the reduction of forest area, the unavailability of clean air produced by forest vegetation and the loss of the function of the forest as a water regulator and preventing erosion. The direct impact of forest fires is as follows. First, the emergence of acute respiratory infections for the community. Secondly, socially and economically the community is disadvantaged because of the reduced efficiency of work, offices, and schools are closed and transportation is disrupted. Third, immaterial and material losses to the local community even cause transboundary haze pollution (cross-boundary smoke pollution) to the region of neighboring countries such as Singapore, Malaysia and Brunei Darussalam. This research discussed one of preventing effort the forest fire by design a new sensing system to detect and estimate the potential of fire in Riau Province, Indonesia. The special type of land which is peatland is one of challenging with new design of sensor and system that difference to others researcher.

Related Works

In this research of forest fire detection used the multi-sensor to achieve accurate information about the potential of forest fire happen. Some literature review on previous works as discussed in [1-3] the use of probabilistic neural networks (PNN) data fusion algorithm to detect the potential of fire based on texture features from the fire scene. Some of the information on the environmental temperature and smoke concentration was collect to be processed by the trend of algorithm separately to the data processed. In [4, 5] elaborate on the design and implementation of a web-based communication module of a multi-sensors, in order to detect fire, a system with a notification system designed. A Global System for Mobile Communication (GSM) technology used which GSM module to send data of fire alerts to representative officer and notification based on the web but subsystem in real-time. The purpose design of web-based notification system is for remote notification and alert of fire.

In [6, 7] discuss on the processing method of the essentially different from the traditional signal. The multi-sensor system information fusion can be merged at different levels. The use of Wi-Fi system to detect fire is applied in [8-10] but the application for indoor as a Wi-Fi signal with the analysis used the fuzzy logic system. The used of Wireless Sensor Network (WSN) system to easily reconfigure its topology in the communication of data. The system applies several numbers of sensor such as temperature, gas concentration, and visibility. The adaptive method based on a multilayer perceptron for the processing of measurement results in a multi-sensor system [11, 12]. The development of the multi-sensor system in the detection of fire apply the algorithms to increase the sensitivity in the detection of fire and some devices implement to reduce nuisance alarms [13, 14].

Wireless multi-sensors for fire detection in WSN node and algorithm is implemented to determine the probability of fire. Fire detection is formed of the low-power electrochemical carbon monoxide sensor, photoelectric smoke detector, and semiconductor temperature sensor. Algorithm for the program in an embedded system is applied as samples of the algorithm were used to derive from the fire detection standard room of the State Key Laboratory of Fire Science of China [15, 16]. Furthermore, a research conducted by the previous researcher is the detection of forest fire in prediction model based on two-stage adaptive duty, then the results obtained be able to detect but some of spot inaccurate. The discussion on the used Internet of Things (IoT) technology in the detection of forest fire as elaborate in [17, 18], this section applies IoT as alerts and broadcast information through IoT system that currently widely used.

Forest fire

Forest fire in Indonesia very often in summer session because of dry environment, many places in Indonesia with rising temperature in summer then easy to get fire on land and forest area. Land and forest fire in Indonesia as a disaster in most provinces, especially in Sumatera and Kalimantan Island because of the peatland area. Table 1 shows the data of forest fire in Indonesia based on province, where Riau province is one of the high and very often getting forest fire.

TABLE 1. Forest Fire Data in Indonesia Year 2014-2019

No	Province	2014	2015	2016	2017	2018	2019	Total (ha)
1	Aceh	155.66	913.27	9,158.45	3,865.16	1,284.70	141.78	15519.02
2	Bali	30	373.46	-	370.8	206.54	-	980.8
3	Bangka Belitung	-	19,770.81	-	-	2,055.67	-	21826.48
4	Banten	2	250.02	-	-	-	-	252.02
5	Bengkulu	5.25	931.76	1,000.39	131.04	8.82	1.47	2078.73
6	DKI Jakarta	-	-	-	-	-	-	0
7	Gorontalo	-	5,225.89	737.91	-	158.65	27.7	6150.15
8	Jambi	3,470.61	115,634.34	8,281.25	109.17	1,390.90	4.18	128890.45
9	Jawa Barat	552.69	2,886.03	-	648.11	4,104.51	-	8191.34
10	Jawa Tengah	159.76	2,471.70	-	6,028.48	331.67	-	8991.61
11	Jawa Timur	4,975.32	7,966.79	-	5,116.43	7,279.76	-	4975.32
12	Kalimantan Barat	3,556.10	93,515.80	9,174.19	7,467.33	68,311.06	2,273.97	180742.35
13	Kalimantan Selatan	341	196,516.77	2,331.96	8,290.34	98,637.99	52.53	306170.59
14	Kalimantan Tengah	4,022.85	583,833.44	6,148.42	1,743.82	41,521.31	27,00	0
15	Kalimantan Timur	325.19	69,352.96	43,136.78	676.38	26,605.57	5,153.07	145249.95
16	Kalimantan Utara	-	14,506.20	2,107.21	82.22	625.82	792.11	18113.56
17	Kepulauan Riau	-	-	67.36	19.61	320.96	4,969.85	5377.78
18	Lampung	22.8	71,326.49	3,201.24	6,177.79	14,963.87	-	95692.19
19	Maluku	179.83	43,281.45	7,834.54	3,918.12	14,131.33	180.03	69345.47
20	Maluku Utara	6.5	13,261.10	103.1	31.1	69.54	56.79	13528.13
21	Nusa Tenggara Barat	3,977.55	2,565.71	706.07	33,120.81	14,352.26	29.10	0
22	Nusa Tenggara Timur	980.87	85,430.86	8,968.09	38,326.09	55,207.64	99.13	189012.68
23	Papua	300	350,005.30	186,571.60	28,767.38	87,676.88	-	653321.16
24	Papua Barat	-	7,964.41	542.09	1,156.03	120.63	58.36	9841.52
25	Riau	6,301.10	183,808.59	85,219.51	6,866.09	37,220.74	27,683.47	347099.5
26	Sulawesi Barat	-	4,989.38	4,133.98	188.13	978.38	56.77	10346.64
27	Sulawesi Selatan	483.1	10,074.32	438.4	1,035.51	1,741.27	441.07	14213.67
28	Sulawesi Tengah	70.73	31,679.88	11,744.40	1,310.19	3,890.95	215.92	48912.07
29	Sulawesi Tenggara	2,410.86	31,763.54	72.42	3,313.68	8,121.35	16.42	45698.27
30	Sulawesi Utara	236.06	4,861.31	2,240.47	103.04	125.07	9.98	0
31	Sumatera Barat	120.5	3,940.14	2,629.82	2,227.43	2,421.90	60.68	11400.47
32	Sumatera Selatan	8,504.86	646,298.80	8,784.91	3,625.66	13,019.68	236.49	680470.4
33	Sumatera Utara	3,219.90	6,010.92	33,028.62	767.98	3,678.79	152.55	46858.76
34	Yogyakarta	0.27	-	-	-	-	-	0.27
TOTAL (ha)		32,438.97	2,012,184.19	429,268.22	125,399.82	447,285.81	42,674.34	3,089,251.35

Peat deposits are generally light brown to dark brown to blackish dark, very soft, easily pricked, dirty hands, if squeezed out the dark liquid and leave remnants of plant waste, obtained from the surface of the earth up to several meters thick. Surface peat deposits can be overgrown with various types and species of plants ranging from moss, bush to large trees. Darker peat usually shows a stronger decay rate. In megascopic tropical peat generally consists of remnants of roots, stems, leaves, and fibers in quantities that are abundant, on the contrary, peat moss (moss peat) is dominated by remnants of moss plants as found in Finland (Northern Europe). Figure 1 shows the area in Indonesia with a high spread of peatland.

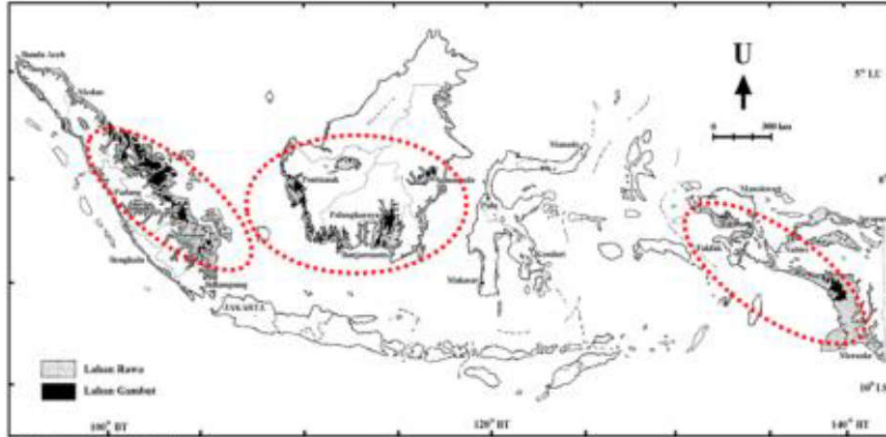

FIGURE 1. Peatland map area in Indonesia.

Proposed Multi Sensor System

Wireless Sensor Networks (WSNs) technology applicable into many applications, such as in industrial automatic control, remote environmental monitoring, target tracking, and remote sensing. The use of WSN system application in an environmental monitoring system which is for detection forest fires in a real-time applied in this research. WSN consists of a numerous number of small nodes in most common situations, which is small nodes deployed in remote and inaccessible hostile environments or over large geographical areas. The deployment of a large number of small sensor nodes to sense environmental changes then report the detection results to sensor base station, then through a gateway to transfer all the data to the server which is the deployment and maintenance should be easy and scalable. Figure 2 shows a block diagram of the design forest fire sensor with multiple sensors.

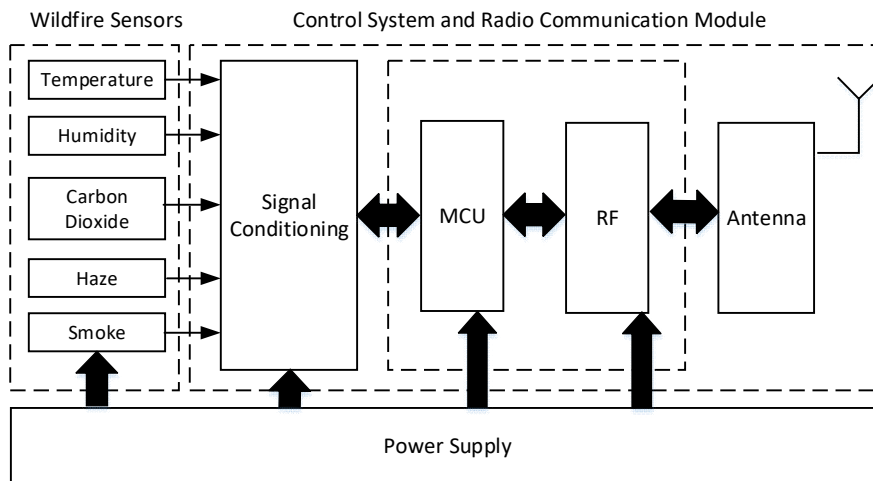

FIGURE 2. Block diagram of forest fire sensor used multiple sensors.

The information detected from the sensors keep in an internal memory of sensor before sending to the monitoring system (backend system), because of the distance between sensor base station to monitoring is very far which in the rural area and up to 200 km. The solar system used for power supply to power up the sensing system. The latest technology of communication system applied in this sensing system which is 4G technology or even 5G technology for future in order to achieve real-time data to display to a monitoring system. Figure 3 shows the block diagram of data communication to the backend system for monitoring.

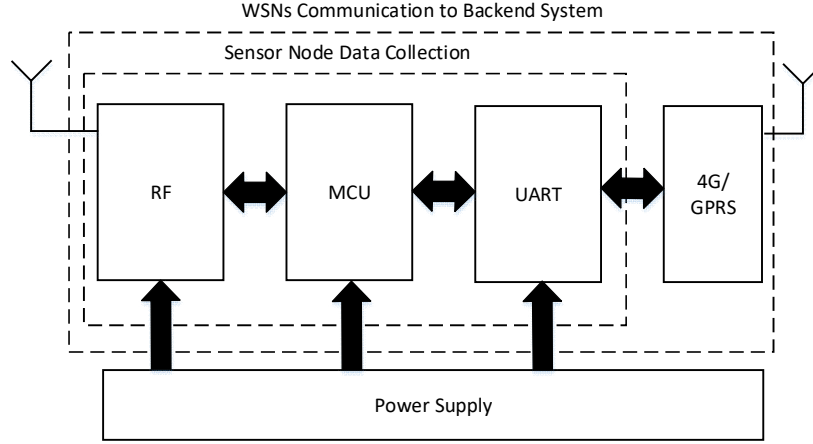

FIGURE 3. Block diagram of communication to backend system.

The design of sensor node for forest fire detection using WSNs system application in peatland area is a new method for ground sensing technology. The data collected base of forest fire parameter and multi sensors to detect abnormal condition. Based of sample data analysis then the design multi sensors system to approach forest fire and material or chemical emit from the forest fire is proposed.

Forest fire modeling in peatland area

In the forest, the total hotspot coverage area can be assuming a set of multiple WSN sensors distributed over a geographical region in the area to be monitor, coverage function P is given as:

$$P = f(x, y, t) = \{(x_1, y_1), \dots, (x_n, y_n)\}$$

$$(x_k, y_k) = f(t), k = 1, 2, 3, \dots, n \quad (1)$$

where (x, y) are coordinates of sensor installed within the coverage monitored area of a fire detection region. In this research, the case network is static without mobile sensor of WSN, but the sensor positions are time-dependent, since the sensor nodes are expected to stop operation in some time. If the case assumes to define the coverage index is IP as a scalar value representing the percentage of coverage area for the detection under the monitoring at a specific time as:

$$IP = \frac{\text{area covered with sensors}}{\text{the total area of the surveillance region}} \cdot 100\% \quad (2)$$

The basic model component is a multiple WSN sensor nodes defined as a vector:

$$S = (d, E(t)) \quad (3)$$

where d is a range of sensor transmitting or radius of transmission area, then the range of covered by radio signal for data exchange with a neighboring node. $E(t)$ is energy available as a power supply for the sensors. Assume a homogenous sensor network with n unified type sensors and one hub-sensor for communication with a dispatcher node.

Network parameters are described as a vector:

$$M = (n, f_0, \Delta E) \quad (4)$$

where n is the number of sensors, f_o is the frequency of regular transmissions, and ΔE is energy consumption per transmission. Assume that sensor nodes periodically transmit the data collected to the neighboring nodes. Energy consumption ΔE includes also energy spent in sensing and data processing. Each node has two roles:

- sensing environmental data and its transmission.
- receiving data from neighboring nodes and forwarding.

The object under surveillance is modeled as four-side stationary polygon defined as a set:

$$O = (A, B, C, D) = \{(x_A, y_A), (x_B, y_B), (x_C, y_C), (x_D, y_D)\} \quad (5)$$

where A , B , C , and D are polygon points with coordinates of (x, y) .

Results and Discussion

The proposed new design of forest fire detection application for peatland area has been tested. The sensors are able to detect all parameters that indicator potential fire in the peatland forest area. The design of the sensor system consists of four sensors which temperature, humidity, smoke, and carbon sensor. Figure 4 shows assembled multiple sensors for detection fire hotspot that consist sensor which related to fire parameters.

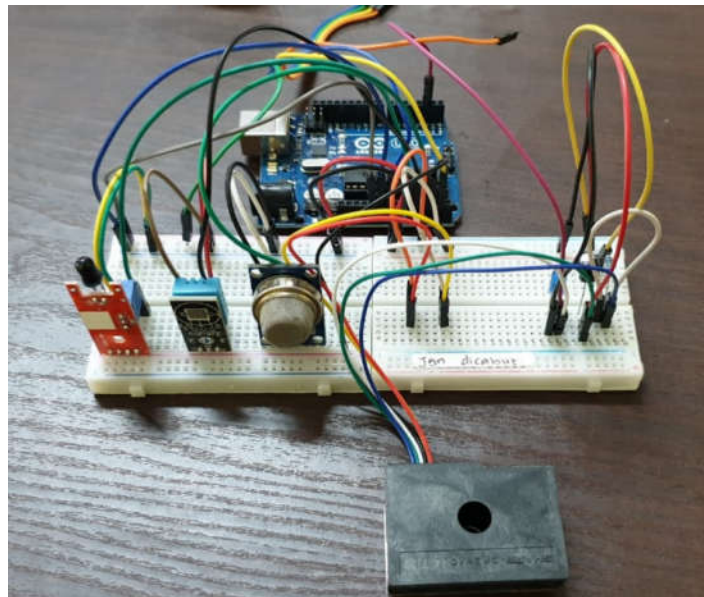

FIGURE 4. Assembled sensor node for fire detection.

The detection data from the sensors keep in the Arduino memory and some filtering has been in this module to avoid waste data. All the data collected from the sensor analyze with an intelligent programming system to determine whether data receive is potential to be a fire, this programming be able to differentiate normal fire and forest or land fire which becomes a wildfire. There are many parameters as discussed in the previous one of the parameter of environmental potential to fire is environment temperature. Beside environment temperature, humidity gives an impact as well to the potential of fire. Measurements of humidity done using sensor and integrated to a temperature sensor in a processing module which is Arduino. Figure 5 shows the assembled and tested of reading humidity in the laboratory environment, the reading of temperature and humidity shows in as LCD display then all the data will log in a data logger inside the module for the record. In a period of time, all the data collected by the Arduino module with filtered data send to the monitoring system that all the data to analyze and permanently record.

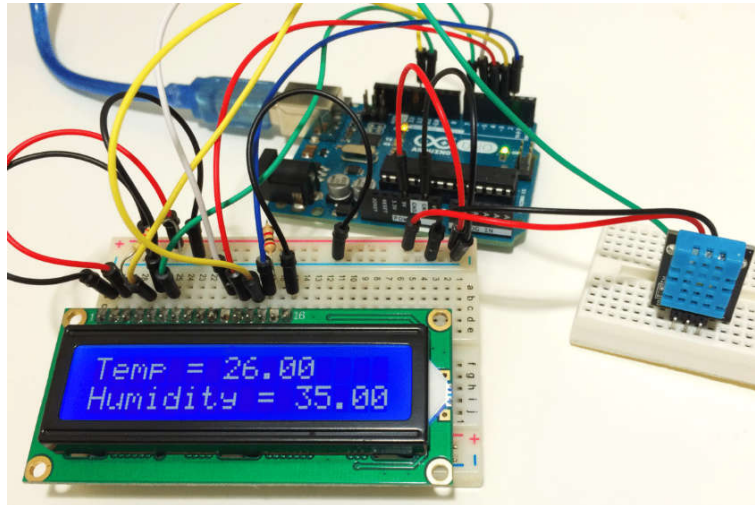

FIGURE 5. Results of testing humidity measurement.

The testing conducted in the real environmental forestry area in dry session. The parameter of basic environmental which temperature and humidity can be group as shown in table 2. The low temperature which 25°C to 27°C is in the night time where the area in tropical region day and night time is the same length. While temperature 35°C to 37°C is most in the day with the hot sun from 12 pm to 3 pm noon.

TABLE 2. Forest Environmental Parameter

NO.	Temperature	Humidity
1		85–90%
2	25–27 °C	90–95%
3		85–90%
4	27–29 °C	90–95%
5		70–75%
6	33–35 °C	85–90%
7		90–95%
8		80–85%
9	35–37 °C	85–90%
10		90–95%

Sensor reading for environmental parameters has been tested in a few time, the basic parameter of environmental tested and the data log in the monitoring system. Figure 9 shows a graph based on data collected for temperature and humidity, based on results shows the relation of temperature versus humidity in forest area is very close thus increasing temperature one of caused forest fire in peatland area. Furthermore, carbon dioxide and haze emitted from a forest fire are some of the indicators that very closely related to cause of fire in peatland area.

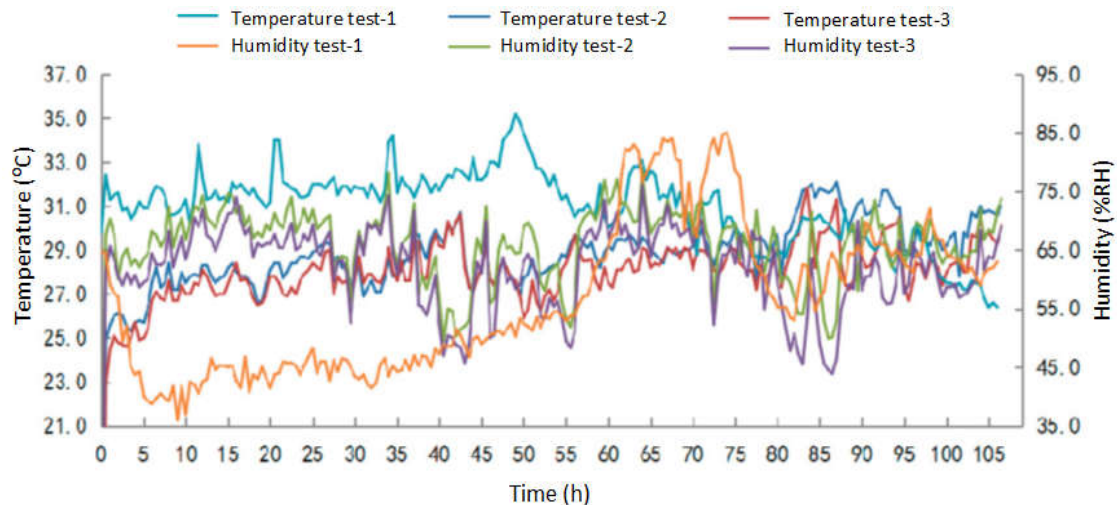

FIGURE 6. Testing results for a period of time in real environmental.

Summary

The design of multiple sensors for forest fire detection and monitoring has been proposed, the results show designed sensor be able to detect basic environmental parameters as the main parameter then some of the additional parameter of forest fire especially in peatland area which different to others normal land or area. The graph shows a strong correlation between increasing temperature versus humidity as well as the reading of carbon emits from the fire and haze concentration one of indicator to justify fire happen. All the reading and detection from the sensor keeps in a data logger for the records. Further enhancement and improvement of the sensing system, as well as data analysis with intelligent programming and algorithm, is one of the targets for future work in this research. Finally, at the end of the project aim to set monitoring system with the mobile report and alert to the community around the forest area as prevention action, notification for authority is a must in this system for action taken.

Acknowledgments

“Authors would like to say thank you very much to KEMENRISTEKDIKTI Indonesia and Universitas Islam Riau, Indonesia for funding this research project and support the facilities”.

References

- [1] X. Chen and L. Bu, "Research of Fire Detection Method Based on Multi-Sensor Data Fusion," in *2010 International Conference on Computational Intelligence and Software Engineering*, 2010, pp. 1-4.
- [2] J. Lin, J. Jian Xun, and W. Yan Xia, "Multi-sensor Fireproof Alarm System," in *2011 International Conference on Applied Superconductivity and Electromagnetic Devices*, 2011, pp. 248-251.
- [3] Y. Yao, J. Yang, C. Huang, and W. Zhu, "Fire Monitoring System Based on Multi-Sensor Information Fusion," in *2010 2nd International Symposium on Information Engineering and Electronic Commerce*, 2010, pp. 1-3.
- [4] R. Sowah, A. R. Ofoli, S. Krakani, and S. Fiawoo, "A web-based communication module design of a real-time multi-sensor fire detection and notification system," in *2014 IEEE Industry Application Society Annual Meeting*, 2014, pp. 1-6.

- [5] Y. Liang and W. Tian, "Multi-sensor Fusion Approach for Fire Alarm Using BP Neural Network," in *2016 International Conference on Intelligent Networking and Collaborative Systems (INCoS)*, 2016, pp. 99-102.
- [6] L. Jiang, Y. Liu, Y. Li, and W. Ma, "Fire prediction based on online sequence extreme learning machine," in *2017 7th IEEE International Conference on Electronics Information and Emergency Communication (ICEIEC)*, 2017, pp. 568-571.
- [7] E. A. Kadir, S. L. Ros, and A. Yulianti, "Application of WSNs for Detection Land and Forest Fire in Riau Province Indonesia," in *International Conference On Electrical Engineering And Computer Science (ICECOS)*, Bangka Belitung, 2018: IEEE.
- [8] A. Yoddumnern, T. Yooyativong, and R. Chaisricharoen, "The wifi multi-sensor network for fire detection mechanism using fuzzy logic with IFTTT process based on cloud," in *2017 14th International Conference on Electrical Engineering/Electronics, Computer, Telecommunications and Information Technology (ECTI-CON)*, 2017, pp. 785-789.
- [9] P. Bolourchi and S. Uysal, "Forest Fire Detection in Wireless Sensor Network Using Fuzzy Logic," in *2013 Fifth International Conference on Computational Intelligence, Communication Systems and Networks*, 2013, pp. 83-87.
- [10] E. A. Kadir, H. Irie, and S. L. Rosa, "Modeling of Wireless Sensor Networks for Detection Land and Forest Fire Hotspot," in *The 18th International Conference on Electronics, Information, and Communication (ICEIC 2019)*, Auckland, New Zealand 2019: IEIE.
- [11] G. F. Malykhina, A. I. Guseva, and A. V. Militsyn, "Early fire prevention in the plant," in *2017 International Conference on Industrial Engineering, Applications and Manufacturing (ICIEAM)*, 2017, pp. 1-4.
- [12] L. Xiujinag, S. Yunfeng, H. Lina, and H. Shangfeng, "The application of multi-sensor weighted measurement fusion filter in fire alarm system," in *2010 International Conference on Computer, Mechatronics, Control and Electronic Engineering*, 2010, vol. 3, pp. 231-234.
- [13] R. Sowah, A. R. Ofoli, S. Krakani, and S. Fiawoo, "Hardware module design of a real-time multi-sensor fire detection and notification system using fuzzy logic," in *2014 IEEE Industry Application Society Annual Meeting*, 2014, pp. 1-6.
- [14] H. Xiangdong and W. Xue, "Application of fuzzy data fusion in multi-sensor fire monitoring," in *2012 International Symposium on Instrumentation & Measurement, Sensor Network and Automation (IMSNA)*, 2012, vol. 1, pp. 157-159.
- [15] H. Hu, G. Wang, Q. Zhang, J. Wang, J. Fang, and Y. Zhang, "Design wireless multi-sensor fire detection and alarm system based on ARM," in *2009 9th International Conference on Electronic Measurement & Instruments*, 2009, pp. 3-285-3-288.
- [16] A. Trucco, F. Traverso, and M. Crocco, "Maximum Constrained Directivity of Oversteered End-Fire Sensor Arrays," *Sensors*, vol. 15, no. 6, pp. 13477-13502, 2015.
- [17] N. Kalatzis *et al.*, "Semantic Interoperability for IoT Platforms in Support of Decision Making: An Experiment on Early Wildfire Detection," *Sensors*, vol. 19, no. 3, pp. 528-567, 2019.
- [18] E. A. Kadir, A. Efendi, and S. L. Rosa, "Application of LoRa WAN Sensor and IoT for Environmental Monitoring in Riau Province Indonesia," in *5th International Conference on Electrical Engineering, Computer Science and Informatics (EECSI 2018)*, Malang, 2018: IEEE.

CERTIFICATE OF APPRECIATION

This Certificate is awarded to

Dr. Evizal

Invited Speaker

The 5th International Conference on Industrial, Mechanical, Electrical,
and Chemical Engineering (ICIMECE 2019)

The Alana Hotel & Convention Center Solo, Indonesia
September 17 - 18, 2019

icimece

Conference Chair



Solo 2019

Dr. Wahyudi Sutopo, S.T., M.Si
NIP. 197706252003121001

Organized by



UNS
UNIVERSITAS
SEBELAS MARET



Dean of Engineering Faculty,
Sebelas Maret University

Dr. Iechan, Jr. Pholihan As'Ad, M.T
NIP. 196710011997021001