

PROCEEDING

ICSET 2019

The Second International Conference on Science,
Engineering and Technology

**“Sustainable Development in Developing
Country for Facing Industrial Revolution 4.0”**

September 5-7, 2019

SKA Convention & Exhibition Center, Pekanbaru, Riau, Indonesia

Organizer :



Co-Organizers :



UNIVERSITI
TEKNOLOGI
MARA



Infrastructure
University
Kuala Lumpur

Multi Parameter of WSNs Sensor Node for River Water Pollution Monitoring System (Siak River, Riau-Indonesia)

Evizal Abdul Kadir¹, Abdul Syukur¹, Bahruddin Saad² and Sri Listia Rosa¹

¹*Department of Informatics Engineering, Faculty of Engineering, Universitas Islam Riau, Pekanbaru, Indonesia*

²*Department of Fundamental and Applied Science Universiti Teknologi PETRONAS Seri Iskandar, Perak, 32610, Malaysia
{evizal, abdulsyukur, srilistiarosa}@eng.uir.ac.id, bahruddin.saad@utp.edu.my*

Keywords: WSNs, Smart Sensor Node, River Water, Pollution.

Abstract: Indonesia is one of the countries that have many rivers and lakes. It is situated, in South East Asia and enjoys tropical climate all year round. Riau province is located in the centre and middle of Sumatera Island which in the heart of Sumatera. This province has more than five big rivers that are used by the community every day for their daily activities. The rapid economic development has significant impact to the region where many industries operating along the river produce industrial wastes that pollutes the river water. This chapter discusses the development of river water monitoring system where several relevant parameters are monitored. The Wireless Sensor Networks (WSNs) applied in this research integrates sensor node that is embed to multi sensor consist of temperature, dissolved oxygen (DO), pH, and electrical conductivity. The system for monitoring is specially design for ability to monitor level of river water, river water flow rate for environment and flood alert system. WSNs sensor nodes collects information from the multiple sensors and forwards to the WSNs sink nodes which embed to the microcontroller memory and unit as a local database before send the information to the monitoring system. The monitoring system shows the vital information that can be monitored by institutions or local authorities. Prompt action will be can be taken if abnormality is raised by the monitoring system. A prototype of this WSNs nodes designed and tested and the results show that sensor nodes are reliable for the detection of polluted water parameters, water levels as well as river flow rate. Furthermore, sensor node was tested at the Siak river located in Riau Province the compare results with actual river water. All the data were keep in the database for recording of analysis and for future development of monitoring system.

1 INTRODUCTION

In some countries, especially the developing country, the rivers remain an significant facilities for daily activities such as transportation, as floating home, shower, washing, and even for cooking for some people. Economics enhancements are boosted by many companies that operating near by the river for support company operation such as transportation and other operation process. In Riau Province has 6 rivers and one of the river is the deepest in Indonesia. There are many industries operating around the river cause severe water pollution and because of the wastes generated and often the unclean environmental operations. Polluted water may contain abnormal parameters.

The conventional methods to check river water quality is testing the sample in laboratory of the river water samples. Though this methods, complete range

of laboratory tests including biological, physical, and chemical parameter are possible but not practical to measure in many points along the river (Zhuiykov, 2012; Lambrou et al., 2012; Aisopou et al., 2012). Additionally, laboratory based tests may need more times to a few days to get the result of the ample and for some parameter maybe the accuracy results less than compare to the actual sample of water changes during testing. Real-time sensor for environment monitoring is start to become popular due to quick advancement in sensing technologies, especially in WSNs that can be adopt in many kinds of applications. The continue collect of river water quality information and the real observation and monitoring applied to check the status of the river and ecosystem and determine the specifics relationship to event detection (Li et al., 2018; Cloete et al., 2016; Kadir et al., 2018b).

Water pollutant monitoring done in previous

research is limited to several parameters and major of monitoring in basic water parameter only parameters (Lambrou et al., 2014; Jinghuan and Yi, 2010; Grossi et al., 2013). Water pollution monitoring system proposed in (Randhawa et al., 2016; Li et al., 2017; Cheng et al., 2016) used multi sensors but limited sensor that only cover basic parameter of water which is temperature and pH, as well as the data keep in local makes incompatible to online remote monitoring. The analysis of water quality using image recognition and by remotely for a long distance monitoring caused accuracy problems (Doña et al., 2014; Olatinwo and Joubert, 2018). Use of robotics in water pollutant monitoring in deep rivers and oceans has obvious advantages but the cost is prohibitive and required skilful operators (Teixidó et al., 2018; Kadir et al., 2018a).

In this research expected to achieve a new system in sensing technology for nodes of WSNs system that ability to achieve multi parameter of water quality at a river in Riau Province, located in Indonesia. Furthermore, the real time based monitoring, system includes river water level and flowrate sensor, parameters that are vital for flood managements during rainy season. In this research contributes to new knowledge and offer new design for river water pollutant monitoring system by data collection, including a new sensor design that is able to collection accurate data. Proposed a new technique of communication from WSNs sensor nodes to gateway via WSNs sink for effectiveness in data sharing and transmission is also an important aim of this research. The use of local and remote data monitoring, a complete monitoring system of interface implement to achieve historical data queries, the real time data and network state to display, data analytical and alarm for abnormal situations is made possible.

2 THE PROPOSED DESIGN OF SENSOR NODES

The proposed new design of sensor nodes in the WSNs for the application in this river water pollutant monitoring system is based in the analysis and initial survey to the field of the actual environmental in Siak river, in Riau Province. In this proposed design several sensors applied to achieve detection for all the parameters of the pollutant index and the river water. Figure 1 shows a scenery of the actual condition of Siak river in Indonesia with activities for the community in daily life such as washing, swimming, fishing and others on the river.



Figure 1: A photograph of Siak river in Riau Province.

The real situation and condition of the river water and river of Siak River in Riau Province, Indonesia is in dirty condition and poses high risk to the ecosystem around the river. Furthermore, people and communities use of river water in their daily activities is very high risk as well. Figure 3 shows of the actual condition of river water polluted and contaminated by chemical and material caused by industries operating around the river (circle bottom left), some of kids playing and swimming in the river as seen in figure 3 at top right. Based on these observations and analysis of water, indicator of some parameters in river water quality is very urgent and required to do a monitoring system for example temperature, dissolved oxygen (DO), pH, and electrical conductivity. The monitoring of river water designed as not only for water pollution monitoring system, but more than that is to make a sensing node where additional sensors can be apply and added. In addition, water flowrate and level measurement is very important as indicator for flooding in the river. Most of rivers located in Riau Province in Indonesia are at very high risk to the flooding because of high intensity of raining and low level to the sea level. The system for flooding alert is very important for reminding the communities for preventive action while water level arise and reach in a dangerous level. The smart of sensor node in WSNs consists of four indicators as indicated for measurement pollutant water and water river status and alert. The indicator as shows in table 1 the complete of indicator measurement with range of sensors and also for the accuracy.

Table 1: Design Specification of the sensor nodes

Parameter	Range	Accuracy	Method
Temperature	0 to 16 °C	± 0.5 °C	Thermistor
DO	0 to 20 mg/L	± 0.5 mg/L	Polarography
pH	0 to 14	± 0.1	Glass Electrode
Salinity	0 to 50 %	± 0.5	Conductivity Measurement

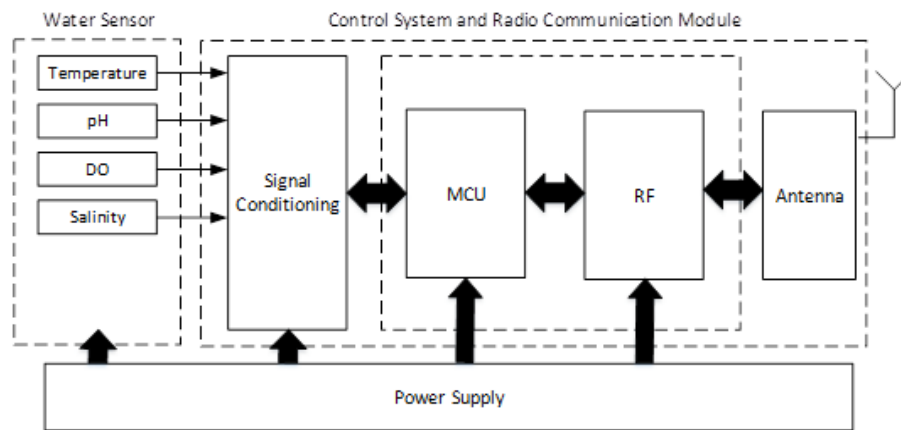

Figure 2: The diagram block of system for smart sensor node in WSNs.



Figure 3: Water polluted by chemicals from an industry operating along river.

In figure 2 shows a diagram block of the smart sensing node for a WSNs system, the data collected by the sensor unit will be keeping in a local storage or database, and then all the analyzed data will be forwarded to central database center at the backend system.

3 MONITORING SYSTEM OF RIVER WATER POLLUTANT

The typical of WSNs in the possesses of the system structure with a new design and novel for the sensor nodes, where simply to configure as an arbitrary of the parameter in the multi parameters in the monitoring network. While compare to the conventional of river monitor system, it consists in the follow discussion:

- The node of sensor are attach with multi sensing and low in power with individual power input used solar panel system.
- The parameter of monitoring are flexible; the

network in sensing on the monitoring area is self-organized

- the size of capacity in the network is very big amount, and the distribution of node can be much deeper.

The information shared to the all of communities. A monitor with all the information related to the water quality installed at the community center or at the point of common assembly of community for easy to delivery of information. Furthermore, all the people and community can have an access to information shows including the status of river water levels. Based on monitoring system then all the information is update for public service and knows the status of the river.

3.1 WSNs System for Water Sensing

A packet of system for sensing complete to all the sensors for detection on how much river water have contaminate installed at the river side in order to obtain, real data on the river flow. As shows in figure 4 illustrate a sensor node that installed on the river side with individual power system which is solar panel. The sensor nodes are normally install with distance very far to the location of monitoring area; thus in this case power supply from normal public service is not available. Thus, the solar powered system with backup battery become very handy.

Large quantity of detection data is collect from any of sensor system then contribute a large number quantity, since the sensor nodes has a limited of storage data, the large data resulted in low of feedback while sending the data to sink node. Multi sensors will affected the sensor nodes performance and also the speed of response. Thus, a smart sensor nodes proposed to design in obtain quick response in case

of abnormal detection on river water monitoring introduced. Introducing an algorithm for the sensor nodes and the filtering of some data gives the sensors node to become smarter in the detection and determine of pollution of the river water. Figure 4 shows a complete of WSNs sensing system for water pollutant detection with all the parameters of polluted water. The system designed in integrated to all parameters including electrical and power supply with individual from solar panel system.

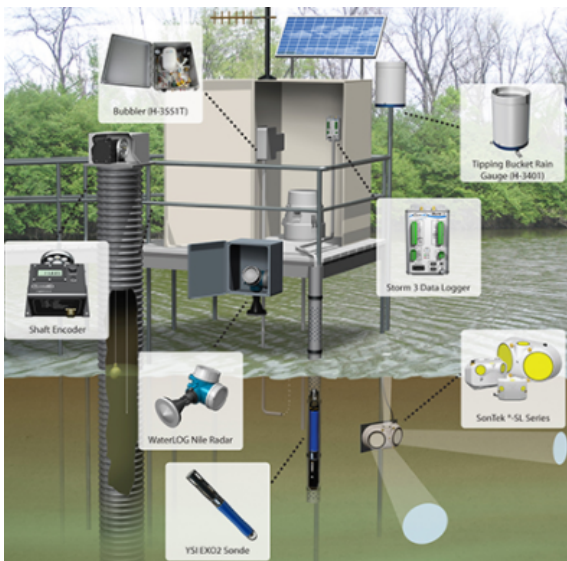

Figure 4: A complete system on the river water side with WSNs node installed for water pollution detection.

3.2 WSNs Sink Node and Communication System

The common of average distance from the sensor nodes is different to the based on early to the data collection by geographical information and survey of the different kind of the river and also the number of the industries operated around the river. In addition, communities in the villages and the activity have contributed to the pollution of river water, to achieve more accurate in data, the average nodes distance must be install as near as possible to the base station. Figure 5 shows, the scenario of topology of the network for the sensor system with the numbers of sensor nodes, in every sensor node have their own sink node to base station for data collecting in a local host before sending to the station of monitoring. In this case, latest communication technology which mobile network Fourth Generation (4G used for sink node as communication to the monitoring station in order for faster communication as well as real time

monitoring system, as so far most of area is a cover by 4G network in mobile cellular or GPRS data.

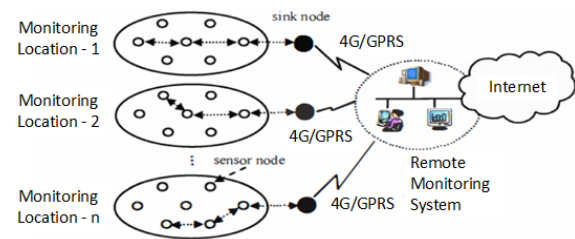

Figure 5: Communication of sensor nodes to the sink and base station system.

4 RESULTS AND DISCUSSION

The simulation results give good response based on test conducted in the laboratory. Data obtain in the tests use as initial as based parameter before the actual testing conducted and sensor installed. In this scenario, initial test results very valuable information in order to conform whether the propose sensor nodes as the model is relevant to apply based on the design of parameter as set. Several of data were compared to other sensors data set and literature as references (Cloete et al., 2016). Result obtain of the temperature sensors as test were compare to conventional measurement which is thermometer (Figure 6).

The parameter of water which pH is another very significant indicator to measure the quality of the water. In this case, the type of sensors uses for sensor nodes built on the glass electrode. The pH sensor design in special specification and precision as in minimum 0.4 pH. There are two classifications of test in conduct to observe the precision of the installed sensor of pH water. In figure 7 shows a water pH sensor while test in the between measurement in the laboratory environment versus to the theoretical analysis which obtain based on simulation and mathematical modeling. Both of results gives good response and agreement and in this measurement can define the pH sensor is working well.

5 CONCLUSIONS

The proposed design of intelligent sensor nodes for WSNs have been done in multi sensor to do measurement of all the parameters in the polluted water. Initial testing in the laboratory give good response and some of sample test conducted to the

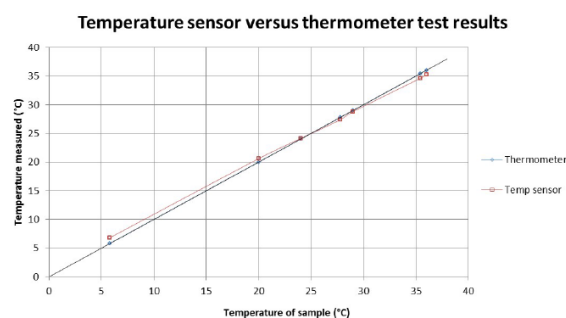

Figure 6: Temperature sensor results vs thermometer.

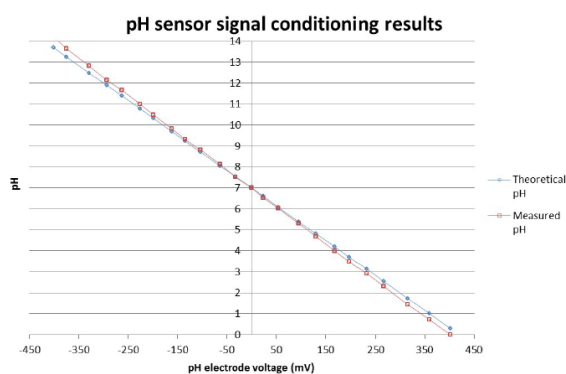

Figure 7: Water pH sensor test between theoretical and actual measurements.

river water, since there are many parameters and chemicals that were involved, thus various sensors such as water temperature were used. Water pH parameters that need to be monitored and water DO. Measurement shows good result and achievement to compared to the analysis and theoretical for all the sensor. Thus, the sensor node can be applied and ready to be deployed to actual sites.

ACKNOWLEDGEMENTS

Thank you very much to KEMENRISTEKDIKTI Indonesia and Universiti Teknologi Petronas for funding this research and Universitas Islam Riau to support the facilities.

REFERENCES

Aisopou, A., Stoianov, I., and Graham, N. J. (2012). In-pipe water quality monitoring in water supply systems under steady and unsteady state flow conditions: A quantitative assessment. *Water research*, 46(1):235–246.

Cheng, M., Guo, Z., Dang, H., He, Y., Zhi, G., Chen, J., Zhang, Y., Zhang, W., and Meng, F. (2016). Assessment of the evolution of nitrate deposition

using remote sensing data over the yangtze river delta, china. *IEEE Journal of Selected Topics in Applied Earth Observations and Remote Sensing*, 9(8):3535–3545.

Cloete, N. A., Malekian, R., and Nair, L. (2016). Design of smart sensors for real-time water quality monitoring. *IEEE Access*, 4:3975–3990.

Doña, C., Sánchez, J. M., Caselles, V., Domínguez, J. A., and Camacho, A. (2014). Empirical relationships for monitoring water quality of lakes and reservoirs through multispectral images. *IEEE Journal of Selected Topics in Applied Earth Observations and Remote Sensing*, 7(5):1632–1641.

Grossi, M., Lazzarini, R., Lanzoni, M., Pompei, A., Matteuzzi, D., and Riccò, B. (2013). A portable sensor with disposable electrodes for water bacterial quality assessment. *IEEE Sensors Journal*, 13(5):1775–1782.

Jinghuan, T. and Yi, W. (2010). A novel water pollution monitoring approach based on 3s technique. In *2010 International Conference on E-Health Networking Digital Ecosystems and Technologies (EDT)*, volume 1, pages 288–290. IEEE.

Kadir, E. A., Irie, H., Rahim, S. K. A., Arta, Y., and Rosa, S. L. (2018a). Reconfigurable mimo antenna for wireless communication based on arduino microcontroller. In *2018 IEEE International RF and Microwave Conference (RFM)*, pages 119–122. IEEE.

Kadir, E. A., Rosa, S. L., and Yulianti, A. (2018b). Application of wsns for detection land and forest fire in riau province indonesia. In *2018 International*

- Conference on Electrical Engineering and Computer Science (ICECOS)*, pages 25–28. IEEE.
- Lambrou, T. P., Anastasiou, C. C., Panayiotou, C. G., and Polycarpou, M. M. (2014). A low-cost sensor network for real-time monitoring and contamination detection in drinking water distribution systems. *IEEE sensors journal*, 14(8):2765–2772.
- Lambrou, T. P., Panayiotou, C. G., and Anastasiou, C. C. (2012). A low-cost system for real time monitoring and assessment of potable water quality at consumer sites. In *SENSORS, 2012 IEEE*, pages 1–4. IEEE.
- Li, L. Y., Jaafar, H., and Ramli, N. H. (2018). Preliminary study of water quality monitoring based on wsn technology. In *2018 International Conference on Computational Approach in Smart Systems Design and Applications (ICASSDA)*, pages 1–7. IEEE.
- Li, T., Xia, M., Chen, J., Zhao, Y., and De Silva, C. (2017). Automated water quality survey and evaluation using an iot platform with mobile sensor nodes. *Sensors*, 17(8):1735.
- Olatinwo, S. and Joubert, T.-H. (2018). Optimizing the energy and throughput of a water-quality monitoring system. *Sensors*, 18(4):1198.
- Randhawa, S., Sandha, S. S., and Srivastava, B. (2016). A multi-sensor process for in-situ monitoring of water pollution in rivers or lakes for high-resolution quantitative and qualitative water quality data. In *2016 IEEE Intl Conference on Computational Science and Engineering (CSE) and IEEE Intl Conference on Embedded and Ubiquitous Computing (EUC) and 15th Intl Symposium on Distributed Computing and Applications for Business Engineering (DCABES)*, pages 122–129. IEEE.
- Teixidó, P., Gómez-Galán, J., Gómez-Bravo, F., Sánchez-Rodríguez, T., Alcina, J., and Aponte, J. (2018). Low-power low-cost wireless flood sensor for smart home systems. *Sensors*, 18(11):3817.
- Zhuyikov, S. (2012). Solid-state sensors monitoring parameters of water quality for the next generation of wireless sensor networks. *Sensors and Actuators B: Chemical*, 161(1):1–20.



CERTIFICATE

ICOSET 2019

== as Presenter ==

This Is To Certify That

EVIZAL ABDUL KADIR

Has Presented At

ICOSET 2019

(THE 2ND INTERNATIONAL CONFERENCE ON SCIENCE, ENGINEERING, AND TECHNOLOGY)

**"SUSTAINABLE DEVELOPMENT IN DEVELOPING COUNTRY
FOR FACING INDUSTRIAL REVOLUTION 4.0"**

on
September 5-7, 2019

at

SKA Convention and Exhibition Center
Pekanbaru - Indonesia

Organized by Universitas Islam Riau



Prof. Dr. H. Syafrinaldi, SH., MCL

General Chair



Dr. Arbi Haza Nasufion, M.IT

CO-ORGANIZERS :



UTM

Infrastructure
University