



APTİKOM

The 7th International Conference
on Informatics and Computing (ICIC) 2022



ICIC 2022 PROGRAM BOOK

8 - 9 DECEMBER 2022



Welcome Message from APTIKOM Chairman



Assalamualaikum warahmatullahi wabarakatuh

A new life style is here. Landscape of things are changed. Technology of industrial revolution 4.0 and Covid-19 become the triggering factors to radical changes. Everything is converted to data. Systems of automation proliferate to profit from the digital age. The workforce landscape shifted as well, moving from traditional workforces to digital workforces. In order to take advantage of and respond to the opportunities and challenges in this disruptive environment, more digital skill sets are required.

The skillset required for the workforce in Indonesia is shown and discussed in ICIC 2022, along with how these landscapes of things and workforces are changing. Our educational systems require a drastic reform. In addition, data driven by business should be established to enhance performances. We must hasten the digital revolution in order to thrive and obtain a competitive advantage. All those issues become the main reason of ICIC 2022 choose the theme of this year conference “*Driving Digital Transformation Toward Society 5.0 through Smart Technology and Artificial Intelligence*”.

We have high hopes that this conference will help promote science and technology in Indonesia and prepare us to embrace society, together with all of our coordinated efforts in education, research, and development, and community activities. 5.0.

Welcome to join ICIC 2022

Thank you

Prof. Ir. Zainal Arifin Hasibuan, PhD.
Head of APTIKOM

Message from the General Chair of ICIC 2022



It is my great pleasure to warmly welcome you to the Seventh International Conference on Informatics and Computing (ICIC 2022) held for the first time, in Hybrid mode. Online participation will be held via the Zoom Meeting platform, while offline event will take place in the land on Bali.

The ICIC is a conference series which is conducted annually by APTIKOM, the Indonesian Association of Higher Education in Informatics and Computing. This year the main theme of the conference is *"Driving Digital Transformation Toward Society 5.0 through Smart Technology and Artificial Intelligence"*, with an intention to bring up more awareness in our society on the importance of Artificial Intelligence in the current era and beyond.

The ICIC conference series as a flagship conference of APTIKOM serves as an arena for academicians and their students, experts and practitioners from the industry to meet, present, and have fruitful discussions on their research works, ideas, and papers in the wide areas of Computing which covers Computer Science, Information Systems, Information Technology, Software Engineering, and Computer Engineering. The conference is set to provide opportunities for participants from both academia and industry to share and exchange knowledge as well as the cutting-edge development in the computing field. It is expected that the ICIC participants will be able to take away new thinking and horizon from this conferential meeting to further their works in the area.

There are 237 papers submission and only 122 papers are accepted which is around 51% acceptance rate. The accepted papers will be presented in one of the 9 regular parallel and tracks sessions and will be published in the conference proceedings volume. The diversity of authors come from 9 different countries.

All accepted papers are submitted to IEEE Xplore. IEEE Conference Number: #56845. Catalog Number: CFP22G52-ART ISBN: 979-8-3503-4571-1

On behalf of the ICIC 2022 organizers, we wish to extend our warm welcome and would like to thank for all Keynote Speakers, Reviewers, Authors, and Committees, for their effort, guidance, contribution and valuable support. We would like to also extend our gratitude to IEEE Indonesia Section for technically co-sponsored this event.

I wish you all a most wonderful, enjoyable, and productive conference in this ICIC 2022.

Thank you.

Wa billahi taufiq wal hidayah. Wallahul muwaffiq ila aqwamit tharieq.

Wasalaamu 'alaykum warahmatullahi wabarakaatuh.

Yusuf Durachman, M.I.T

Organizing Chair

The 2022 International Conference on Informatics and Computing (ICIC)

Committee

Steering Committee:

Zainal A. Hasibuan, Dian Nuswantoro University, Indonesia
Achmad Benny Mutiara, Gunadarma University, Indonesia

General Chair:

Yusuf Durachman, UIN Syarif Hidayatullah Jakarta, Indonesia

Program Co-chair:

Husni Teja Sukmana, UIN Syarif Hidayatullah Jakarta, Indonesia
Prihandoko, Gunadarma University, Indonesia
Anton Satria Prabuwono, King Abdulaziz University, Saudi Arabia

Publication Co-chairs:

Dwiza Riana, STMIK Nusa Mandiri, Indonesia
Dewi Khairani, UIN Syarif Hidayatullah Jakarta, Indonesia
Dian Syafitri, STMIK Bumigora Mataram, Indonesia

Publicity Co-chairs:

Solikin, University of Bina Insani, Indonesia
Hanny Hikmayanti Handayani, University of Buana Perjuangan Karawang, Indonesia
Yuhandri, University of Putra Indonesia YPTK Padang, Indonesia

Technical Program Committee Co-chair:

Achmad Nizar Hidayanto, Universitas of Indonesia, Indonesia
Husni Teja Sukmana, UIN Syarif Hidayatullah Jakarta, Indonesia

Web Development:

Dewi Khairani, UIN Syarif Hidayatullah Jakarta, Indonesia
Deden Wahiddin, University of Buana Perjuangan Karawang, Indonesia

TPC members:

Doni Purnama Alamsyah Bina Nusantara University
Indra Budi Fasilkom UI
Esmeralda Djamal Universitas Jenderal Achmad Yani
Syarifuddin Dr. STIE Sebelas April
Yusuf Durachman State Islamic University of Syarif Hidayatullah Jakarta
Arfive Gandhi Telkom University
Rahmadya Handayanto universitas islam 45
Tri Handhika Gunadarma University
Dr. Muhammad Said Hasibuan IBI Darmajaya
Henderi Henderi Universitas Raharja
Nanang Husin Universitas Negeri Surabaya



Dedi Iskandar Inan University of Technology, Sydney
Norhaslinda Kamaruddin MARA University of Technology
Sandy Kosasi STMIK Pontianak
Robby Kurniawan Harahap Gunadarma University
Dr. Uky Yudatama M.Kom Universitas Muhammadiyah Magelang
Purnawarman Musa Gunadarma University
Achmad Benny Mutiara Gunadarma University
Achmad Nizar University of Indonesia
Cecilia Nugraheni Parahyangan Catholic University
Eri Prasetyo Gunadarma University
Dr. Heny Pratiwi STMIK Widya Cipta Dharma
Prihandoko Prihandoko Universitas Gunadarma
Tri Kuntoro Priyambodo Universitas Gadjah Mada
Untung Rahardja Universitas Raharja
Arief Ramadhan Binus University
Dwiza Riana STMIK Nusa Mandiri
Ridwan Sanjaya Soegijapranata Catholic University, Indonesia
Harry B. Santoso Faculty of Computer Science, Universitas Indonesia
Sunny Arief Sudiro STMIK Jakarta STI&K
Sukemi Sukemi Universitas Sriwijaya
Husni Teja Sukmana Syarif Hidayatullah State Islamic University Jakarta
Aries Susanto UIN Syarif Hidayatullah Jakarta
Evi Triandini Institut Teknologi dan Bisnis STIKOM Bali
Helna Wardhana Universitas Bumigora
Retantyo Wardoyo Universitas Gadjah Mada
Andree E. Widjaja Universitas Pelita Harapan

Program Structures

Thursday, December 8th, 2022

TIME*	PROGRAM	PIC/SPEAKERS	VENUE
08.00 - 08.45	Author and Participant Registration	ICIC Committee	Denpasar Room (3 rd FL)
09.00 - 09.45	Keynote Session ICIC Speaker: Moderator:	ICIC Committee	Virtual Onsite: Denpasar Room (3 rd FL) (PIC: Ricky)
09.45 - 10.00	Coffee Break	ICIC Committee	TBA / Parallel Room 4 th FL
10.00 - 12.00	Parallel session I ICIC	ICIC Committee	Parallel Room 4 th FL PIC1: Arsa PIC2: Arya Budi (Breakout room Zoom)
12.00 - 13.00	Lunch	ICIC Committee	Ground FL Restaurant
13.00 - 14.45	ICIC Opening join with APTIKOM National Conference (MUNAS)		Griya Agung Ballroom (2 nd Floor)
14.45 - 15.00	Coffee Break		TBA/ Parallel Room 4 th FL
15.00 - 17.00	Parallel session II ICIC	ICIC Committee	Parallel Room 4 th FL (Breakout room Zoom)
17.30 - 18.00	ICIC Closing	ICIC Committee	Denpasar Room (3 rd FL)

*) All time are in Central Indonesia time (WITA), or UTC +8

Presentation Schedule

DAY	TIME	Track 1 - TABANAN ROOM Chair: Prof Sri Hartati Host: I KM Dwiki Wahyu Danuarta	Track 2 - AMLAPURA ROOM Chair: Agus Hardjoko Host: Rolla Adi Prawira	Track 3 - BANGLI ROOM Chair: Henderi Host: I Dewa Gede Bagus Suyoga	Track 4 - SINGARAJA ROOM Chair: Dedi. I Inan Host: Natalia Sastra Guna
THURSDAY 8 Nov 2022	Session 1 10.00-12.00	CS/I 3 Onsite	CS/I 24 Onsite	CS/I 55 Onsite	IS/IT 161 Onsite
		CS/I 17 Onsite	CS/I 31 Onsite	CS/I 59 Onsite	IS/IT 163 Onsite
		CS/I 18 Onsite	CS/I 39 Onsite	CS/I 61 Onsite	IS/IT 214 Onsite
		CS/I 76 Onsite	CS/I 54 Onsite	CS/I 86 Onsite	IS/IT 134 Onsite
		CS/I 75 Onsite	CS/I 112 Onsite	CS/I 183 Onsite	SE 33 Onsite
		CS/I 74 Onsite	CS/I 117 Onsite	CS/I 190 Onsite	SE 123 Onsite
		CS/I 98 Onsite	CS/I 172 Onsite	CS/I 208 Onsite	SE 193 Onsite
		CS/I 104 Onsite	CS/I 181 Onsite	CS/I 141 Onsite	IS/IT 158 Onsite
	Session 2 15.00-17.00	Track 1 - TABANAN ROOM Chair: Dr. Heni Jusuf, M.Kom Host: I KM Dwiki Wahyu Danuarta	Track 2 - AMLAPURA ROOM Chair: Dedi. I Inan Host: Rolla Adi Prawira	Track 3 - BANGLI ROOM Chair: Henderi Host: I Dewa Gede Bagus Suyoga	Track 4 - SINGARAJA ROOM Chair: Sandy Kosasi Host: Natalia Sastra Guna
		IS/IT 49 Onsite	IS/IT 93 Onsite	MM 207 Onsite	CS/I 171 Onsite
		IS/IT 53 Onsite	IS/IT 95 Onsite	MM 1 Onsite	CS/I 176 Onsite
		IS/IT 68 Onsite	IS/IT 92 Onsite	MM 206 Onsite	CS/I 121 Onsite
		IS/IT 100 Onsite	IS/IT 115 Onsite	MM 122 Onsite	CS/I 225 Onsite
		CE/CS 57 Onsite	CE/CS 91 Onsite	IS/IT 209 Onsite	IS/IT 228 Onsite
		CE/CS 65 Onsite	CE/CS 195 Onsite	IS/IT 213 Onsite	IS/IT 232 Onsite
		CE/CS 23 Onsite	CE/CS 82 Onsite	IS/IT 41 Onsite	IS/IT 235 Onsite
CE/CS 84 Onsite		IS/IT 12 Onsite			

DAY	TIME	Track 5 Chair: Dr. Bambang Krismono Host: Putu Handika Permana	Track 6 Chair: M Said Hasibuan Host: I Gusti Made Raditya Adi Wiguna	Track 7 Chair: Dr. Rangga Firdaus Host: Ni Putu Devi Putri	Track 8 Chair: Herlino Nanang, PhD Host: Ni Nyoman Yuspita Dewi	Track 9 Chair: Lasmedi Afuan Host: Ni Nyoman Arie Rahayu
THURSDAY 8 Nov 2022	Session 1 10.00-12.00	CS/I 36 Virtual	CS/I 148 Virtual	IS/IT 13 Virtual	IS/IT 126 Virtual	CS/I 229 Virtual
		CS/I 37 Virtual	CS/I 154 Virtual	IS/IT 28 Virtual	IS/IT 136 Virtual	CS/I 230 Virtual
		CS/I 51 Virtual	CS/I 170 Virtual	IS/IT 46 Virtual	IS/IT 137 Virtual	CS/I 233 Virtual
		CS/I 67 Virtual	CS/I 175 Virtual	IS/IT 52 Virtual	IS/IT 192 Virtual	IS/IT 237 Virtual
		CS/I 108 Virtual	CS/I 184 Virtual	IS/IT 69 Virtual	IS/IT 200 Virtual	IS/IT 226 Virtual
		CS/I 139 Virtual	CS/I 186 Virtual	IS/IT 72 Virtual	IS/IT 202 Virtual	IS/IT 236 Virtual
		CS/I 146 Virtual	CS/I 199 Virtual	IS/IT 94 Virtual	IS/IT 216 Virtual	CE/CS 231 Virtual
		CS/I 147 Virtual	CS/I 234 Virtual	IS/IT 116 Virtual	IS/IT 223 Virtual	CE/CS 90 Virtual
	Session 2 15.00-17.00	Track 5 Chair: Dr. Bambang Krismono Host: Putu Handika Permana	Track 6 Chair: M Said Hasibuan Host: I Gusti Made Raditya Adi Wiguna	Track 7 Chair: Dr. Rangga Firdaus Host: Ni Putu Devi Putri	Track 8 Chair: Sunny Arief Sudiro Host: Ni Nyoman Yuspita Dewi	
		CE/CS 27 Virtual	CS/I 22 Virtual	CS/I 70 Virtual	IS/IT 44 Virtual	
		CE/CS 50 Virtual	CS/I 191 Virtual	CS/I 79 Virtual	IS/IT 106 Virtual	
		CE/CS 66 Virtual	CS/I 205 Virtual	CS/I 101 Virtual	IS/IT 85 Virtual	
		CE/CS 198 Virtual	CS/I 119 Virtual	CS/I 103 Virtual	IS/IT 224 Virtual	
		CS/I 14 Virtual	CS/I 110 Virtual	SE 107 Virtual	CS/I 2 Virtual	
		CS/I 182 Virtual	CS/I 77 Virtual	SE 135 Virtual	CS/I 40 Virtual	
		MM 15 Virtual	CS/I 187 Virtual	SE 16 Virtual	CS/I 62 Virtual	
MM 179 Virtual		IS/IT 227 Virtual	CS/I 73 Virtual			

***) All time are in Central Indonesia time (WITA), or UTC +8**

Link Zoom:

<https://us02web.zoom.us/j/89497273675?pwd=MEY3bkxmSitWZm9NUGRiWDNiQlqrUT09>

Meeting ID: 894 9727 3675

Passcode: icic2022

Tracks:

CE/CS CE and Computer Systems

CS/I CS and Informatics

MM Multimedia

IS/IT IS, IT and Management

SE Software Engineering

Presentation Schedule Session 1 – 10.00 – 12.00

Track 1 - TABANAN ROOM		
Chair: Prof Sri Hartati		
Host: I KM Dwiki Wahyu Danuarta		
CS/I	3	The Estimating of Nutrient Value in Apples Based on Size Employing the Canny Edge Detection Algorithm Anis Fitri Nur Masruriyah, Muhammad Haidar Ijlal, Rahmat Rahmat, Hanny Hikmayanti Handayani, Deden Wahiddin and Ahmad Fauzi
CS/I	17	Garbage Classification Using CNN Architecture ShuffleNet v2 Eka Setya Wijaya, Andy Mizwar, Ahmad Mujaddid Islami, Yuslena Sari, Erika Maulidiya and Irham Maulani Abdul Gani
CS/I	18	Bankruptcy Prediction using Ensemble Support Vector Machine Nurul Fathanah Mustamin, Jeffry, Supriyadi La Wungo, Firman Aziz and Nurafni Shahnbyb
CS/I	76	Comparison of Smoothing Methods for Noise Reduction on Baseline Electroencephalogram Signals I Made Agus Wirawan, Retantyo Wardoyo, Danang Lelono and Sri Kusrohmaniah
CS/I	75	Improvising Low Contrast Malaria Images Using Contrast Enhancement Techniques on Various Color Models Doni Setyawan, Retantyo Wardoyo, Moh Wibowo and E. Elsa Hardiana Murhandarwati
CS/I	74	A Study on Text Feature Selection Using Ant Colony and Grey Wolf Optimization Joan Angelina Widians, Retantyo Wardoyo and Sri Hartati
CS/I	98	Analysis of Face Data Augmentation in Various Poses for Face Recognition Model T.M. Syahril Nur Alamsyah, Taufik Abidin, Ridha Ferdhiana, Muhammad Dirhamsyah and Muhammad Chaidir
CS/I	104	Dual Cluster Head Selection Based on LEACH and Differential Search Algorithm to Extend Network Lifetime in Wireless Sensor Network Kun Nursyaiful Priyo Pamungkas, Supeno Djanali, Radityo Anggoro, Paliling, Puhrani Burhan and Feriyadi

Track 2 - AMLAPURA ROOM		
Chair: Agus Hardjoko		
Host: Rolla Adi Prawira		
CS/I	24	Public Sentiment Analysis of Indonesian Tweets About COVID-19 Vaccination Using Different Machine Learning Approaches Valentinus Paramarta, Adele Mailangkay, Hilda Amalia and Desta Christmas
CS/I	31	Fire Detection In Wetland Using YOLOv4 And Deep Learning Architecture Andreyan Rizky Baskara, Yuslena Sari, Auria Andeni Anugerah, Eka Setya Wijaya and Ricardus Anggi Pramunendar
CS/I	39	A Systematic Literature Review Enhanced Felder Silverman Learning Style Models (FSLSM) Supangat Supangat and Mohd Zainuri Bin Saringat
CS/I	54	Vanishing Point Detection using Angle-based Hough Transform and RANSAC Dea Angelia Kamil, Agus Harjoko and Wahyono Wahyono
CS/I	112	Systematic Literature Review of Text Feature Extraction: Research Trends, Datasets, and Methods Agus Mulyanto, Sri Hartati and Retantyo Wardoyo
CS/I	117	A Time-Window Approach to Recommending Emerging and On-the-rise Items Tubagus Mohammad Akhriza and Indah Dwi Mumpuni
CS/I	172	Energy Efficiency in Buildings Using Multivariate Extreme Gradient Boosting Triando Hamonangan Saragih, Rahmat Ramadhani, Muhammad Itqan Mazdadi and Muhammad Haekal
CS/I	181	Sentiment Classification of Visitors in Yogyakarta Palace using Support Vector Machine Cahaya Damarjati, Fadia Rani and Slamet Riyadi

Track 3 - BANGLI ROOM			
Chair: Henderi			
Host: I Dewa Gede Bagus Suyoga			
CS/I	55	Classification and Sentiment Analysis on Tweets of the Ministry of Health Republic of Indonesia	Apriandy Angdresey, Indah Yessi Kairupan and Kenshin Gerald Emor
CS/I	59	Conditional Random Field for Crime News Information Extraction with SMOTE	Viny Christanti Mawardi, Veronika Veronika and Dali Santun Naga
CS/I	61	The Implementation of Real-ESRGAN as An Anticipation to Reduce CER Value in Plate Number Extraction Results Employing EasyOCR	Geo Septian, Deden Wahiddin, Hilda Novita, Hanny Hikmayanti Handayani, Ayu Ratna and Anis Fitri Nur Masruriyah
CS/I	86	Classification of Chili Plant Condition based on Color and Texture Features	Deffa Rahadiyan, Sri Hartati, Wahyono Wahyono and Andri Prima Nugroho
CS/I	183	Hate Speech Detection in Code-Mixed Indonesian Social Media: Exploiting Multilingual Languages Resources	Endang Wahyu Pamungkas, Azizah Fatmawati, Dedi Gunawan, Yusuf Sulisty Nugroho and Endah Sudarmilah
CS/I	190	Comparison of Convolutional Neural Network Models to Detect Covid-19 on CT-Scan Images	Slamet Riyadi, Suci Rahmadina M. Rasyid and Cahya Damariati
CS/I	208	Analysis of Indonesian Discussion Tendency on Twitter with Text Classification	Reyvan Rizky Irsandy and Ayu Purwarianti
CS/I	141	1D Convolutional Neural Network to Detect Ventricular Fibrillation	Sava Savero, Muammar Sadrawi and David Agustriawan

Track 4 - SINGARAJA ROOM			
Chair: Dedi. I Inan			
Host: Natalia Sastra Guna			
IS/IT	161	Adaptation on Education after Covid-19 – Optimizing Cognitive Load on Nervous System Science Learning for Higher Education Students through the Usage of Chunking Style Animation in Social Learning Media	Ng Melissa Angga, Cicilia Caroline Phieranto, Fonny Tejo, Dionisius Yovan, Angelica Angelica and Felicia Sumarsono Putri
IS/IT	163	Topic Modeling for Cyber Threat Intelligence (CTI)	Hatma Suryotrisongko, Hari Ginardi, Saeed Dehqan and Yasuo Musashi
IS/IT	214	Evaluation of Enterprise Resource Planning (ERP) and Open-source ERP Modification for Performance Improvement	Ananda and Jansen Wiratama
IS/IT	134	M-Government Adoption in Indonesia: Self-Determination Theory	Dedi I. Inan, Achmad Nizar Hidayanto, Ratna Juita, Antares Firman, Ali Muktiyanto, Hermawan Wibisana Arifin, Muhammad Rizky Darmawan, Nabilla Yuli Shafira and Cassie Michelle
SE	33	Design and Build a Attendance System and Employee Performance Assessment with a Website-Based Profile Matching Method	Hata Maulana, Noorlela Marcheta, Asep Taufik Muharram, Kamil Raihan Permana and Alifiah Putri Aisyah
SE	123	GeoJSON Implementation for Demographic and Geographic Data Integration Using RESTful Web Services	Alam Rahmatulloh, Bambang Tri Handoko, Rahmi Nur Shofa and Irfan Darmawan
SE	193	Development of Portal Signer for Digital Products by Using Iterative Model at PT RST	Manogunawan Resqi Gultom, Riyanthi Angrainy Sianturi, Rince Septriana Parhusip, Ova Ferdinan Marbun and Yohanssen Pratama
IS/IT	158	Adoption Technology at MSMEs: A Conceptual Model with TOE	Evi Triandini, I Gusti Ngurah Satria Wijaya, I Ketut Putu Suniantara and Sugiarto Sugiarto

Presentation Schedule Session 2 – 10.00-12.00 (VIRTUAL)

Track 5		
Chair: Dr. Bambang Krismono		
Host: Putu Handika Permana		
CS/I	36	Comparison of the K-Nearest Neighbor and Decision Tree algorithm to the Sentiment Analysis of Investment Applications Users in Indonesia Doni Purnama Alamsyah, Rizkiansyah Rizkiansyah and Asti Herliana
CS/I	37	Investigation of Netizen Sentiment Analysis Toward The Controversy of Information and Electronic Transaction Law Fahdi Saidi Lubis, Muharman Lubis and Lukmanul Hakim
CS/I	51	Sentiment Analysis of "Hepatitis of Unknown Origin" on Social Media using Machine Learning Nova Agustina, Harya Gusdevi, Iis Ismawati, Diyah Wijayati and Candra Nur Ihsan
CS/I	67	Multiclass Intent Classification for Chatbot Based on Machine Learning Algorithm Wan Mohd Amir Fazamin Wan Hamzah, Mohd Kamir Yusof, Ismahafezi Ismail, Mokhairi Makhtar, Hasnah Nawang and Azwa Abdul Aziz
CS/I	108	Low Cloud Type Classification System Using Convolutional Neural Network Algorithm Muhammad Naufal Fikriansyah, Hapsoro Agung Nugroho and Marzuki Sinambela
CS/I	139	Rice seed classification using machine learning and deep learning Budi Dwi Satoto, Devie Rosa Anamisa, Budi Irmawati, Muhammad Yusuf, Mohammad Kautsar Sophan and Siti Oryza Khairunnisa
CS/I	146	Analysis for Data Mobility and Covid-19 Positive Rate with Multilayer Perceptron Arie Vatesia, Ruvita Faurina and Riki Zulfahmi
CS/I	147	Multibranch Convolutional Neural Network For Gender And Age Identification Using Multiclass Classification And FaceNet Model Haris Setiawan, Mudrik Alaydrus and Abdi Wahab

Track 6		
Chair: M Said Hasibuan		
Host: I Gusti Made Raditya Adi Wiguna		
CS/I	148	Detecting Online Outlier for Data Streams using Recursive Residual Yasi Dani
CS/I	154	Implementation of Adaptive Bit Decision Point to Improve Receiver Performance in Li-Fi System Juan S. Biantong, Mudrik Alaydrus and Ahmad Sony Alfathani
CS/I	170	LongSpam: Spam Email Detection using LSTM Algorithm Nurhadi Wijaya
CS/I	175	LSTM and ARIMA for Forecasting COVID-19 Positive and Mortality Cases in Indonesia Syafrial Fachri Pane, Adiwijaya Adiwijaya, Mahmud Dwi Sulistiyo and Alfian Akbar Gozali
CS/I	184	Semantic Segmentation of Landsat Satellite Imagery Herlawati Herlawati, Rahmadya Trias Handayanto, Prima Dina Atika, Sugiyatno Sugiyatno, Rasim Rasim and Mujiarso Mujiarso
CS/I	186	DeepRec: Efficient Product Recommendation Model for E-Commerce using CNN Hamzah Hamzah, Erizal Erizal and Mohammad Diqi
CS/I	199	Adopting Haar Cascade Algorithm on Mask Detection System Based on Distance Jemakmun Jemakmun, Rudi Suhirja, Darius Antoni, Hadi Syaputra and Darius Antoni
CS/I	234	E-Archive Document Clustering Information System Using K-Means Algorithm Aida Fitriyani, Wowon Priatna, Dani Yusuf, Tri Dharma, Sri Rejeki and Amri Amri

Track 7		
Chair: Dr. Rangga Firdaus		
Host: Ni Putu Devi Putri		
IS/IT	13 The Influence of The COVID-19 Pandemics in Indonesia On Predicting Economic Sectors	Heriyanto Heriyanto, Syafrial Fachri Pane, Aji Gautama Putrada, Nur Alamsyah and Mohamad Nurkamal Fauzan
IS/IT	28 Validation and Verification of Business Architecture Process Based On The V . Model	Widia Febriyani, Firna Muningsgar Kistianti and Muharman Lubis
IS/IT	46 Acceptance Rate Analysis of Internal Management Operational Application on Pt. Sigma Cipta Caraka Using Technology Acceptance Model (TAM)	Fatimah Azzahra Ashari, Muhammad Qamra Zahran Muharam, Junia Himmayati and Teguh Prasandy
IS/IT	52 ONLINE LEARNING AND STUDENTS' ETHICAL BEHAVIOR DURING COVID-19: FOR BETTER OR FOR WORSE? CASE STUDY FOR CREATIVEPRENEURSHIP STUDY PROGRAM, BINUS BANDUNG	Febri Tri Intan Azhana, Rosita Widjojo, Khusnul Khotimah, Doni Purnama Alam Syah, Muchamad Rizky Zakaria and Balqis Putri Hidayatullah
IS/IT	69 Analysis of Design Implementation Guidelines for Data Governance Management Based on DAMADMBOKv2	Fadhil Rozi Hendrawan, Tien Fabrianti Kusumasari and Rokhman Fauzi
IS/IT	72 Enterprise Architecture Planning based on One Data in Indonesian Higher Education	Hery Dian Septama, Muhamad Komarudin, Puput Budi Wintoro, Mahendra Pratama, Titin Yulianti and Bambang Sundari
IS/IT	94 Motivation and Drivers for Online Fashion Rental: Study by Social Networking Sites in Indonesia	Margareth Setiawan, Sandy Setiawan, Aris Darisman and Rosyidah Rahmah
IS/IT	116 Model Implementation of Application Programming Interface for E-Government Data Integration	Agus Sifaunajah, Tholib Hariono, Moh. Anshori Aris Widya, Primaadi Airlangga, Sujono and Siti Sufaidah

Track 8		
Chair: Herlino Nanang, PhD		
Host: Ni Nyoman Yuspita Dewi		
IS/IT	126 Android-based Matrix Learning Media to Increase Student Interest in Learning	Isna Wardiah, Rahimi Fitri, Reza Fauzan, Seberan and Fuad Sholihin
IS/IT	136 Digital Transformation Impact Analysis towards Transition in the Role of Information Technology for Organization in New Digital Bank	Yosua Pangihutan Sagala, Muhammad Akmal Juniawan, Vina Ardelia Effendy, Rahmawati Putrianasari, Vien Aulia Rahmatika, Muhammad Rifki Shihab and Benny Ranti
IS/IT	137 Analysis of Critical Success Factors in Information Technology Projects: A National Shipping Company Case Study	Ivan Eka Aditya, Ardhy Wisdarioanto and Teguh Raharjo
IS/IT	192 User Experience Evaluation of IT Support Mobile Application Using System Usability Scale (SUS) and Retrospective Think Aloud (RTA)	Imanuel Revelino, Sunardi Sunardi, Ratih Muthiah Kamilia, Ganis Maulia Yusuf and Rizki Kurniawan
IS/IT	200 Impact of Leadership in Transitioning IT Roles from Turnaround to Strategic: Case Study of PT. XYZ	Paulus Donny Junianto, Rizal Fathoni Aji and Ryan Randy Suryono
IS/IT	202 Usability Evaluation on Educational Chatbot using the System Usability Scale (SUS)	Arief Hidayat, Agung Nugroho and Safa'Ah Nurfa'izin
IS/IT	216 Adaptivo: A Personalized Adaptive E-Learning System based on Learning Style and Prior Knowledge	Mohammed Rishard, Sandaru Jayasekara, Piumi Ekanayake, Jayani Wickramathilake, Kalpani Manathunga and Jagath Wickramaratne
IS/IT	223 Data Balance Optimization of Fraud Classification for E-Commerce Transaction	Aida Fitriyani, Wowon Priatna, Dani Yusuf, Tri Dharma, Sri Rejeki and Amri Amri

Track 9 Chair: Lasmedi Afuan Host: Ni Nyoman Arie Rahayu		
CS/I	229	Optimization Analysis of Neural Network Algorithms Using Bagging Techniques on Classification of Date Fruit Types Rully Pramudita, Solikin Solikin and Nadya Safitri
CS/I	230	Machine Learning Model Based on REST API for Predicting Tenders Winner Mardi Yudhi Putra, Rachmad Nur Hayat, Ahmad Chusyairi, Dwi Ismiyana Putri and Solikin Solikin
CS/I	233	Implementation of Discrete Cosine Transform and Permutation-Substitution Scheme Based on Henon Chaotic Map for Images Andrean Lius, Eric Eric, Irgan Pardosi and Hernawati Gohzali
IS/IT	237	THE INFLUENCE OF BLENDED LEARNING WITH FLIPPED CLASSROOM MODEL ON MOTIVATION IN LEARNING GEOGRAPHY Nur Azizah, Jakiatin Nisa, Syairul Bahar, Andri Noor Ardiansyah and Abd. Rozak
IS/IT	226	Implementation of Internship Decision Support System Using Simple Multi Attribute Rating Technique (SMART) Pajri Aprilio and Sy Yuliani
IS/IT	236	Towards Tourism Management Platform for Culinary Tourism Management and Merchandise E-Catalogs Nurul Firdaus, Salsabila Fithriyah, Hartatik H, Agus Purbayu, Fiddin Yusufida A'La and Berliana Kusuma Riasti
CE/CS	231	IoT-Based Smart Bin Using Smell, Weight, And Height Sensors Abraham Bulyan Zebua, Muhammad Fahrul Azmi Husni, Muhammad Naufal, Andri Andri and Syanti Irviantina
CE/CS	90	Face Recognition System Using Feature Extraction Method of 2-D Gabor Wavelet Filter Bank and Distance-Based Similarity Measures R Rizal Isnanto, Ajub Ajulian Zahra and Andre Lukito Kurniawan

Presentation Schedule Session 2 – 15.00 – 17.00

Track 1 - TABANAN ROOM			
Chair: Dr. Heni Jusuf, M.Kom			
Host: I KM Dwiki Wahyu Danuarta			
IS/IT	49	Examining User Acceptance of MOOCs: The Role of Openness, Task Technology Fit, and Social Recognition	Bernardinus Harnadi, Fx Prasetya and Albertus Widianoro
IS/IT	53	ISO 15489 Attributes Prioritization in Electronic Document Management System of the First Level Healthcare Facilities	Intan Dzikria, Luvia Friska Narulita, Agus Hermanto and Geri Kusnanto
IS/IT	68	IoT-Agri: IoT-based Environment Control and Monitoring System for Agriculture	Adimas Ketut Nalendra, Dona Wahyudi, M Mujiono, M. Nur Fuad and Ni'Ma Kholila
IS/IT	100	Utilization of Linguistic Data for Learner Assessment on e-Learning: Instrument and Processing	Wenty Dwi Yuniarti, Sri Hartati, Sigit Priyanta and Herman Dwi Surjono
CE/CS	57	Can We Predict Our Electricity Consumption?	Apriandy Angdresey, Lanny Sitanayah and Zefanya Marieke Philia Rumpesak
CE/CS	65	Learner Action Patterns in the Problem-Solving Process Related to Program Code Composition Based on Tracking System Activities	Aulia Akhrian Syahidi, Ahmad Afif Supianto, Tsukasa Hirashima and Yutaka Watanobe
CE/CS	23	Mobile Application Performance Improvement with the Implementation of Code Refactor Based on Code Smells Identification: Dutataniku Agriculture Mobile App Case Study	Argo Wibowo, Antonius Rachmat Chrismanto, Maria Nila Anggia Rini and Lukas Chrisantyo
CE/CS	84	Oil Well Monitoring System Based on IoT Technology and Machine Learning	Evizal Abdul Kadir, Muslim Abdurrahman, Sharul Kamal Abdul Rahim, Agus Arsad, Sri Listia Rosa and Apri Siswanto

Track 2 - AMLAPURA ROOM			
Chair: Dedi. I Inan			
Host: Rolla Adi Prawira			
IS/IT	93	Adaptive Cooling System for Comfortable Learning	David Habsara Hareva
IS/IT	95	UT Metaverse: Beyond Universitas Terbuka Governance Transformation and Open Challenges	Antares Firman, Ali Muktiyanto, Dedi I. Inan, Ratna Juita, Ghassan Beydoun and Daryono Daryono
IS/IT	92	The Follower-Influencer Experience Affecting the Intention to Follow Recommendation: PAD Perspective	Dedi I. Inan, Achmad Nizar Hidayanto, Ratna Juita, Adam Maulana, Dinda Mutiara Qur'Ani Putri, Muhammad Fariz Farhan, Siti Kaamiliaa Hasnaa and Marlinda Sanglise
IS/IT	115	Food Vloggers: Mapping the Relationships between Personal Relevance, Customer Engagement, and Repurchase Decision	Arif Murti Rozamuri, Johan Setiawan, Christian Haposan Pangaribuan, Hidayanti, Tri Wismiarsi and Maria Wahyuni
CE/CS	91	Design of Blind Community Assistance Devices with Indoor Positioning System Technology	Cen Choi Bong, David Habsara Hareva and Samuel Lukas
CE/CS	195	Portable Monitoring Systems for Rivers Based on Internet of Things	Henderi Henderi, Mumammad Hudzaifah Nasrullah, Laura Belani Nudiyah, Po Abas Sunarya, Jana Utama and Didik Setiyadi
CE/CS	82	An experimental study on binary optimization using quantum annealing in D-Wave	Nongmeikapam Brajabidhu Singh, Gopal Krishna, Arnab Roy, Joseph L Pachuau and Anish Kumar Saha

Track 3 - BANGLI ROOM		
Chair: Henderi		
Host: I Dewa Gede Bagus Suyoga		
MM	207	Learn Japanese Vocabulary and Hiragana Letters with Augmented Reality for Indonesian Children Riri Safitri, Resnia Trya Muslima and Sandra Herlina
MM	1	Aw...The Museum is so "Dark": The Effect of Thermal Stimuli for Virtual Reality Experience and Emotion Gabriel Indra Widi Tamtama, Halim Budi Santoso, Jyun-Cheng Wang and Nila Armelia Windasari
MM	206	Interaction Design of Indonesian Anti Hoax Chatbot Ryan Daniel, Ayu Purwarianti and Dessi Puji Lestari
MM	122	Automatic Determination of Seeded Region Growing Parameters in Watershed Regions to Segmentation of Tuna Wanvy Arifha Saputra, Agus Zainal Arifin, Nuruddin Wiranda, Edi Yohanes, Zainal Abidin and Bambang Suriansyah
IS/IT	209	Usability Improvement Through User Interface Design With Human Centered Design (HCD) Method On Junior High School Websites Saepul Aripriyanto, Riana Munawarohman, Muhamad Azhari, Siti Umami Masruroh, Dewi Khairani and Husni Teja Sukmana
IS/IT	213	Educational question classification with Graph Neural Network Said Al Faraby, Adiwijaya Adiwijaya and Ade Romadhony
IS/IT	41	A Systematic Literature Review of Barriers and Drivers E-Government in Developing Countries: TOE Framework Perspective Dony Martinus Sihotang, Bambang Aria Yudhistira, Solikin, Dana I Sensuse, Achmad Nizar Hidayanto, Widijanto Satyo Nugroho and Wahyu Catur Wibowo
IS/IT	12	Influence of Electronic Word Of Mouth (e-WOM), Hedonic Motivation, and Price Value On Consumer's Purchase Intention Using Social Commerce "TikTok Shop" Mutia Maulida, Yuslena Sari and Siti Rohmah

Track 4 - SINGARAJA ROOM		
Chair: Sandy Kosasi		
Host: Natalia Sastra Guna		
CS/I	171	Improving Candle Direction Classification in Forex Market using Support Vector Machine with Hyperparameters Tuning Raymond Oetama, Yaya Heryadi, Lukas Lukas and Wayan Suparta
CS/I	176	Sentiment Analysis on Cryptocurrency Based on Tweets and Retweets Using Support Vector Machines and Chi-Square Isabella Donita Hasan, Raymond Oetama and Aldo Lionel Saonard
CS/I	121	Prediction of Work From Home Post COVID-19 using Classification Model Risanti Galuh and Johan Setiawan
CS/I	225	A Floor Cleaning Based-Robotic Combines a Microcontroller And A Smartphone Jafar Shadiq, Rita Wahyuni Arifin, Bayu Aji Prayoga and Solikin Solikin
IS/IT	228	Travel Budget Prediction for Determining Tourism Objects Using Simple Additive Weighting (SAW) Algorithm H Hartatik, Nurul Firdaus, Rudi Hartono, Berliana Kusuma Riasti, Agus Purbayu and Fiddin Yusufida A'La
IS/IT	232	The role of management technology and innovation strategy in business strategy based on a user perspective Nina Kurnia Hikmawati, Yusuf Durachman, Husni Teja Sukmana and Herlino Nanang
IS/IT	235	USABILITY TESTING ANALYSIS OF COMPANY WEBSITE SYSTEM IN INDONESIA Yusuf Durachman

Presentation Schedule Session 2 – 15.00 – 17.00 (VIRTUAL)

Track 5			
Chair: Dr. Bambang Krismono			
Host: Putu Handika Permana			
CE/CS	27	Modeling and Simulation of Long Range (LoRa) Communication System on Smart Grid	Isminarti Isminarti, Amil Ahmad Ilham, Ardiaty Arief and Syafaruddin Syafaruddin
CE/CS	50	Follicle Detection Model on Ovarian Ultrasound Image	Sri Hartati, Aina Musdholifah, Putu Desiana Wulaning Ayu and Jaswadi Dasuki
CE/CS	66	Mobile Device Positioning by Using Dynamic Weighted Centroid Model	Rifki Kosasih and Ahmad Sabri
CE/CS	198	Monitoring Indoor Air Quality for Thermal Comfort using Internet of Things	Rahmi Andarini and Moeljono Widjaja
CS/I	14	A PSO-GBR Solution for Association Rule Optimization on Supermarket Sales	Syafrial Fachri Pane, Aji Gautama Putrada, Nur Alamsyah and Mohamad Nurkamal Fauzan
CS/I	182	The Comparison of Sentiment Analysis Algorithm for Fake Review Detection of The Leading Online Stores in Indonesia	Pius Hans Christian and Ririn Ikana Desanti
MM	15	SI-BIME Smart Learning Multimedia Platform for Students: a Solutions for the Pandemic-19 in the Regions	Dina Fitria Murad, Titan Titan, Taufik Darwis and Hardiyansyah Hardiyansyah
MM	179	Augmented Reality English Education Based iOS with MobileNetV2 Image Recognition Model	Doni Purnama Alamsyah, Yudi Ramdhani, Ahmad Setiadi and Agus Tiyansyah Syam

Track 6			
Chair: M Said Hasibuan			
Host: I Gusti Made Raditya Adi Wiguna			
CS/I	22	Text Normalization on Code-Mixed Twitter Text using Language Detection	Rafi Dwi Rizqullah and Indra Budi
CS/I	191	Data Pipeline Framework for AIS Data Processing	Ni Kadek Bumi Krismentari, I Made Oka Widyantara, Ngurah Indra Er, I Made Dwi Putra Asana, I Putu Noven Hartawan and I Gede Sudiantara
CS/I	205	Real Time Web-based Facemask Detection Implementation	Geraldo Pan, Suryasari Suryasari, Haditya Setiawan and Aminuddin Rizal
CS/I	119	Topic Modeling on COVID-19 Vaccination in Indonesia Using LDA Model	Nurul Mutiah, Dian Prawira and Ibnur Rusi
CS/I	110	Dynamic Pricing Analytic of Airbnb Amsterdam Using K-Means Clustering	Fitrianingsih Fitrianingsih and Figa Rizfa
CS/I	77	Decision Tree Algorithm in Visual Novel Game using RenPy Games Engine	Diena Rauda Ramdania, Maisevli Harika, Maulana Hamdani, Yana Aditia Gerhana, Nurhadi Qomaruddin, Cepy Slamet and Dian Sa'Adillah Maylawati
CS/I	187	Analyze and Improve Production Process Using VSM Method: A Case Study of Microplate HT96 Production at PT. Promanufacture Indonesia	Muh Ikhsan and Sri Susilawati Islam

Track 7 Chair: Dr. Rangga Firdaus Host: Ni Putu Devi Putri			
CS/I	70	Implementation of Modified Linear Congruent Methods in Randomizing Exam Questions to Optimize the Learning Environment	Maxrizal Maxrizal, Sujono Sujono, Baiq Desy Aniska Prayanti and Syafrul Irawadi
CS/I	79	New Approach of Covid-19 Prevention by Implemented Combination of Decision Support System Algorithm	Eddy Soeryanto Soegoto, Yeffry Handoko Putra, Rahma Wahdiniwati, Zuriani Ahmad Zukarnain and Noorihan Abdul Rahman
CS/I	101	Grading Problem-Solving for Clustering Students' Score Using Dynamic Programming Procedure in The Context of Dynamic Time Warping	Mochamad Nizar Palefi Ma'Ady, Tabina Shafa Nabila Syahda, Muhammad Nasrullah, Anindya Salwa Salsabila, Ulyy Asfari and Hawwin Mardhiana
CS/I	103	Preprocessing 7-Phases Based On Extractive Text Summarization	Adhika Pramita Widyassari, Noersasongko Edy, Syukur Abdul and Affandy
SE	107	Blockchain-Based Multiple Server Database System Prototype on BMKG Automatic Weather Station (AWS) Center Architecture	Handi Sutriyan, Agung Sunaryadi and Marzuki Sinambela
SE	135	Games for Scrum Team Collaboration in the Global Software Development Environment: A Literature Review	Anita Hidayati, Iklima Ermis Ismail, Ade Rahma Yuly and Henry Edison
SE	16	Designing Mobile Banking Prototype Using Design Thinking Approach (Case Study: BPD Bali Mobile)	A. A. Istri Ita Paramitha, I Ketut Agus Juliana, Ketut Queena Fredlina, Helmy Syakh Alam, I Made Artana and I Nyoman Yudi Anggara Wijaya
IS/IT	227	Implementation of One Data-based Lecturer Profile Information System for Key Performance Indicator Monitoring	Hery Dian Septama, Muhamad Komarudin, Puput Budi Wintoro, Mahendra Pratama, Titin Yulianti and Wahyu Eko Sulistiono

Track 8 Chair: Sunny Arief Sudiro Host: Ni Nyoman Yuspita Dewi			
IS/IT	44	User Experience Analysis Using Usability Testing on Library and Knowledge Center BINUS University with SmartPLS	Dyaz Aerlangga, Rifky Muhammad Arsy, Gunawan Sunardy and Teguh Prasandy
IS/IT	106	Evaluation of Acceptance of the Use of Social Media on the Application of Blended Learning in Private Higher Education in Indonesia	Fahmi Yusuf, Aang Subiyakto and Titik Khawa Abdul Rahman
IS/IT	85	Gamification using Octalysis Framework in Knowledge Management System for Vocational High Schools during the Covid-19 Pandemic	Mgs. Afriyan Firdaus, Dwi Rosa Indah, Yoppy Sazaki, Eka Prasetyo Ariefin, Muhammad Fachri Nuriza and Muhammad Rafly
IS/IT	224	YoBagi's User Experience Evaluation using User Experience Questionnaire	Fransiskus Panca Juniawan, Dwi Yuny Sylfania, Rendy Rian Chrisna Putra and Henderi Henderi
CS/I	2	Random Forest Classifier Based on Genetic Algorithm Optimization for Heart Failure Prediction	Maria Ulfah Siregar, Ichsan Setiawan, Najmunda Zia Akmal and Dewi Wisnu Wardani
CS/I	40	Prediction of Automobiles Prices Using Exploratory Data Analysis Based on Improved Machine Learning Techniques	Fadhil Muhammad Basysyar, Ferisanti Ferisanti, Maryam Wulandari, Indah Sucitra, Dian Ade Kurnia and Solikin Solikin
CS/I	62	Air Temperature Prediction Using Autoregressive Artificial Neural Network Method with Variations of The Number of Hidden Layer	Christine Lusiana Debataraaja, Mudrik Alaydrus and Umaisaroh Umaisaroh
CS/I	73	Spelling Correction Using the Levenshtein Distance and Nazief and Adriani Algorithm for Keyword Search Process Indonesian Qur'an Translation	Muhammad Iskandar Yahya, Arini Arini, Victor Amrizal and Iik Muhamad Malik Matin

Oil Well Monitoring System Based on IoT Technology and Machine Learning

Abstract -

The process of crude oil mining in oil wells takes a long time and requires good supervision to avoid unwanted things. This process requires full 24-hours monitoring of oil parameters such as oil temperature and flow rate. Currently, the supervision process is still done manually which may occur some errors. Based on this fact, this paper aims to design a surveillance or monitoring system that is more effective and efficient. The testing of this monitoring system uses an oil pump machine prototype with the assistance of a MAX-6675 temperature sensor and an ultrasonic flowmeter TUF-2000m as well as a sensor TM-1 transducer as an input tool. Raspberry Pi 3 as a microcontroller and a web application as an output that displays data in the form of graphs. The test stage is carried out by heating the temperature sensor, slowing down the flow of oil on the prototype, and checking the values displayed on the graph. The results of the test when the temperature sensor received heat, the microcontroller ran well, as evidenced by the data that was successfully stored on the web server and a graph showing the increase in the oil temperature value. Likewise with the flow rate sensor when it receives resistance or the flow is slowed down, the graph shows a decrease in the flow rate value in the oil. With the results of this test, the prototype of the monitoring system on oil wells with the Internet of Things (IoT) technology runs as expected, namely being able to monitor the value of oil parameters in real-time which allows effectiveness and efficiency in work to increase.

Keywords: Oil Well, Monitoring System, Internet of Things

Host:



Sponsored by:



Co-Host:



Oil Well Monitoring System Based on IoT Technology and Machine Learning

Evizal Abdul Kadir
Department of Informatics Engineering
Universitas Islam Riau
Pekanbaru, 28284 Indonesia
evizal@eng.uir.ac.id

Muslim Abdurrahman
Department of Petroleum Engineering
Universitas Islam Riau
Pekanbaru, 28284 Indonesia
muslim@eng.uir.ac.id

Sharul Kamal Abdul Rahim
Wireless Communication Centre
Universiti Teknologi Malaysia
Johor Bahru, 81310 Malaysia
sharulkamal@fke.utm.my

Agus Arsad
UTM-MPRC Institute for Oil and Gas
Universiti Teknologi Malaysia
Johor Bahru, 81310 Malaysia
agus@utm.my

Sri Listia Rosa
Department of Informatics Engineering
Universitas Islam Riau
Pekanbaru, 28284 Indonesia
srilistiarosa@eng.uir.ac.id

Apri Siswanto
Department of Informatics Engineering
Universitas Islam Riau
Pekanbaru, 28284 Indonesia
aprisiswanto@eng.uir.ac.id

Abstract — The process of crude oil mining in oil wells takes a long time and requires good supervision to avoid unwanted things. This process requires full 24-hours monitoring of oil parameters such as oil temperature and flow rate. Currently, the supervision process is still done manually which may occur some errors. Based on this fact, this paper aims to design a surveillance or monitoring system that is more effective and efficient. The testing of this monitoring system uses an oil pump machine prototype with the assistance of a MAX-6675 temperature sensor and an ultrasonic flowmeter TUF-2000m as well as a sensor TM-1 transducer as an input tool. Raspberry Pi 3 as a microcontroller and a web application as an output that displays data in the form of graphs. The test stage is carried out by heating the temperature sensor, slowing down the flow of oil on the prototype, and checking the values displayed on the graph. The results of the test when the temperature sensor received heat, the microcontroller ran well, as evidenced by the data that was successfully stored on the web server and a graph showing the increase in the oil temperature value. Likewise with the flow rate sensor when it receives resistance or the flow is slowed down, the graph shows a decrease in the flow rate value in the oil. With the results of this test, the prototype of the monitoring system on oil wells with the Internet of Things (IoT) technology runs as expected, namely being able to monitor the value of oil parameters in real-time which allows effectiveness and efficiency in work to increase.

Keywords—Oil Well, Monitoring System, Internet of Things

I. INTRODUCTION

Energy is an important part of human life, without enough energy economic activity will slow down. Most of the energy used by humans comes from fossils, one of which is crude oil. This oil has been separated from natural gas after the extraction or mining process because crude oil is found together with natural gas [1]. Crude oil is a non-renewable natural resource, in the form of a dark brown or dark brown liquid or it can be greenish and has several very complex carbon chains, therefore crude oil is of high economic value. Data based on the central statistics agency shows that crude oil production in Indonesia in 2020 reached 259 million barrels [2]. Meanwhile, crude oil reserves reached 4.17 billion barrels. This figure certainly illustrates that the production of crude oil and natural gas in Indonesia is still very large. However, the oil reserve does not mean that it can be obtained easily, the process of extracting oil from oil wells

requires a systematic process and design of tools, starting from the design of pipes, pumps, and monitoring sensors that are very necessary. The process of extracting crude oil or fluids from production wells (oil wells) through a piping system is carried out in two ways, namely by using the individual system, flow line or by using a production line system is pumped to the Gathering Station (GS), the type of equipment used in the GS is generally largely determined by the parameters of temperature, pressure, and the resulting fluid.

Several works have been done the previous research related to the oil well monitoring system in a petroleum company, especially in the downstream process. Research on the monitoring of oil parameters and indicators for example liquid flow rate in the pipeline as discussed in [3-7]. The research monitors for a parameter and then sends the information to a database at the data center. While other research is to monitor oil well parameters using an ultrasonic sensor to find the values of flow and water content as elaborate in the [8-10], the discussion the how much sensitivity in the sensor to various sample pipeline sizes. The size and thickness of the pipe affected the sensitivity and reading of the sensor to the actual flow rate, a calibration in measurement and testing is required to achieve actual values. In the [11-12] discussion on monitoring water content in a pipeline near to oil well, the research to find how much water percentage in a well then, the percentage of oil from the pump at the oil well. While [13-14] elaborates on the flow sensing system to detect and monitor abnormality in a pipeline at the oil well. The discussion of the oil well monitoring system to retrieve well information for example pump status, voltage, current, and flow as well as the temperature as discussed in the [15-16].

This research aims to design a new model of a monitoring system for oil wells using IoT and store all the well data and information in a cloud system. Wireless monitoring systems apply to get the information that is a constraint for the remote location of the well. The proposed monitoring system has a new design with several sensor connected to each other's then sending all the information to the backend system for analysis as well as displaying the information on the command center.

II. MONITORING AND SYSTEM DESIGN

Currently, the monitoring system on the oil well is running on the conventional method in which every sensor installed in each pipe will be checked by the officer periodically or manually written to find out the value of the parameters generated by the crude oil extraction process, sometimes even checking is only done when a problem occurs that does not occur. wanted. Figure 1 shows the illustrated of the physical oil well on the field for pumping the oil from the ground.



Fig. 1. Illustrated of oil well on the field and parts to monitor

A. Conventional Oil Well Monitoring System

The value of the oil well parameter will determine various things such as production level, pipe safety, and so on. Based on the analysis of the current system, the following is an overview of the current system analysis. Figure 2 shows a conventional method of monitoring oil wells by directly visiting the site and recording manually on the sheet. Several instruments are installed on the oil well to monitor performance and production of the well, there are important parts to monitor such as temperature, flowrate, pump status, pressure including power supply which voltage and current supplied to well.

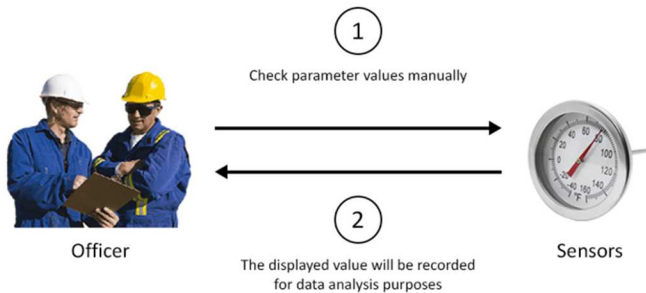

Fig. 2. Conventional monitoring of oil well

B. Digital Oil Well Monitoring System

The proposed new method is to monitor the oil well indicator by digitalizing the system by installing the sensor to all the equipment and parameter would like to check and measure. The procedure analysis of this system is necessary to know the current procedures for designing the new system. Figure 3 shows the design of the following is an overview of the current system and proposed digital system for the oil well.

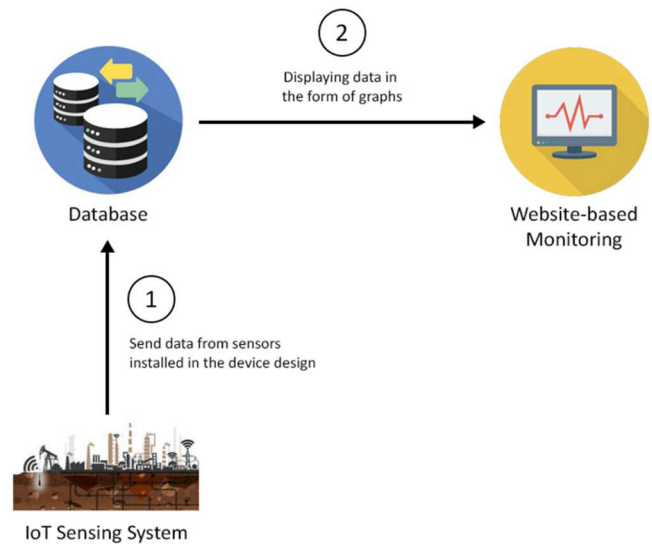

Fig. 3. Architecture of monitoring system in oil well

The use of an oil pump for the engine and prototype has many advantages, including minimizing the risk of accidents that could occur in the actual oil well area. In addition, by using a prototype, trials can be freely carried out many times and are not limited in time. The prototype that will be used is available in-house in the Laboratory, Faculty of Engineering, Islamic University of Riau. In this research, an ultrasonic flow meter model TUF-2000M was used with the help of a transducer model TM-1 which was installed with the method installation method. This sensor is installed on the outside of the pipe which is placed after the pump, and the temperature sensor used is the MAX-6675 sensor, installed into the pipe to read the temperature of the oil that is flowing. Here is the photo. Figure 4 shows the prototype of the oil well monitoring system while figuring 4(a) the full unit with a circulating pump system and figure 4(b) the sensor used in the prototype system for monitoring temperature and flow rate. The prototype can run as scenarios that we trying to simulate according to the actual operation on the field.



(a)



(b)

Fig. 4. Prototype of oil well monitoring system (a) the full unit of oil well with the circulate pump (b) sensor used in the prototype

The Raspberry Pi 4 microcontroller is needed in the initial data processing, its function is to receive data from sensors and forward it to the web server. The microcontroller sends data to the web server using a post request technique using the HTTP request library. The tool used and simulation has been done in the laboratory to check and monitor the system in a few days. Figure 5 shows a block diagram of the system and Raspberry Pi 4 microcontroller module used in this prototype of a system.

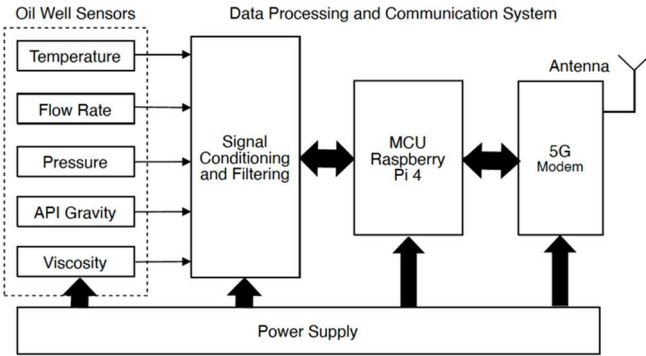

Fig. 5. Block diagram of monitoring system in oil well

System workflow design is a step-by-step process of describing how to sample test data sent within the system. And to produce oil, many processes are carried out and take a very long time, one of the processes is the extraction or mining process of oil, the results of which will be pumped into the GS through gathering pipes, and to find out how it works, a workflow design is made. The system workflow starts by checking the sensor and reading raw data using the flowrate sensor, this data will then be sent to the Raspberry Pi 3 microcontroller. After the data is received, the microcontroller will then check whether there is internet access, if there is data will be sent directly to the web server, else the data will be stored in the local database. All data stored in the local database will be sent to the web server when the microcontroller is connected to the internet. Figure 6 shows a flowchart of the entire monitoring process of the oil well in the field. All the data is stored in a database for accessing by the system in anytime at anywhere by pushing the data to a cloud computing.

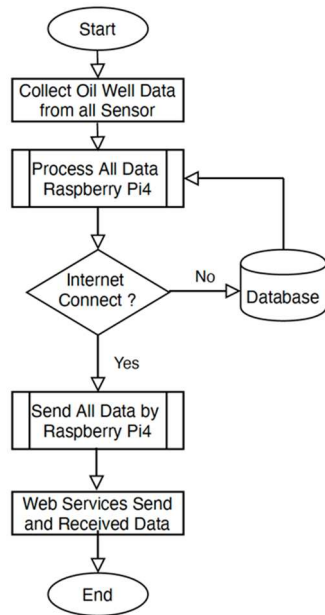

Fig. 6. Flowchart of the process of oil well monitoring

C. LSTM Algorithm

The proposed method is different compared to other techniques as discussed previously, in that the LSTM deep learning algorithm applied with a big number of training data and testing data achieves high accuracy forecasting results for the specific case in the Indonesia region. Python programming is used in simulation and analysis as it is one of the high-level programs with a fast process, and it is applied in many kinds of deep learning algorithms. Figure 7 shows the structure of the RNN of the LSTM Algorithm.

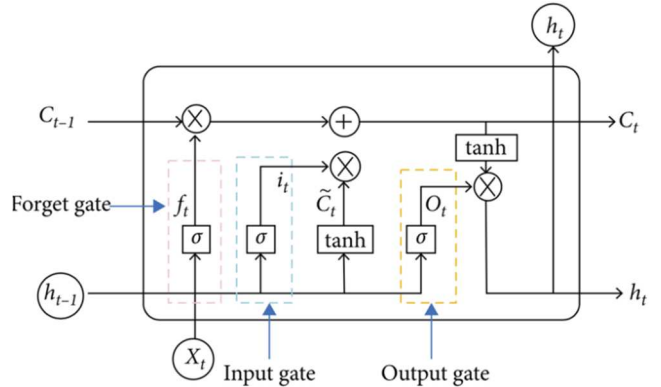

Fig. 7. Structure of the RNN-LSTM Algorithm

LSTM is divided in to two parts of the RNN's hidden state memory cell which the C_t and the h_t working memory. These memory cells are responsible for the retention of sequence features. The memory of the previous sequence is controlled by the forgetting gate f working memory, and h_t is used as output, and the output gate O controls the portion of the current memory C_t to be written as an input, i controls the portion of the current state information h_{t-1} and the current input X_t to be written to the memory cell. The three types of

gates above are not static. The previous state information h_{t-1} and the current input X_t are determined together through nonlinear activation after linear combination. The LSTM model consists of three major cells, and each cell can be written as Equations (1)–(6).

$$f_t = \sigma(W_f \cdot [h_{t-1}, x_t] + b_f) \quad (1)$$

$$i_t = \sigma(W_i \cdot [h_{t-1}, x_t] + b_i) \quad (2)$$

$$\tilde{C}_t = \tanh(W_c \cdot [h_{t-1}, x_t] + b_c) \quad (3)$$

$$C_t = f_t * C_{t-1} + i_t * \tilde{C}_t \quad (4)$$

$$o_t = \sigma(W_o \cdot [h_{t-1}, x_t] + b_o) \quad (5)$$

$$h_t = o_t * \tanh(C_t) \quad (6)$$

where w_f , w_i , w_c , and w_o are weight matrixes of b_f , b_i , b_c , and b_o are bias vectors, \tilde{C}_t is the new candidate state generated by x_t and h_{t-1} through the *tanh* layer, and σ is the sigmoid activation function.

Figure 8 shows a complete prototype oil well system, while several sensors are embedded in the system to obtain actual data from the well. The prototype can demonstrate how the actual process in the well as the representative of the actual well in the site.

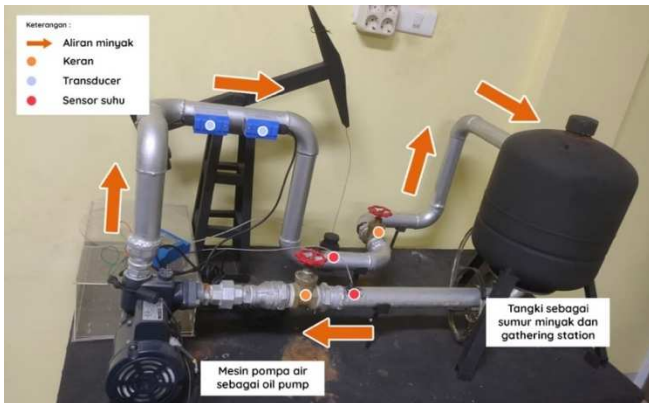
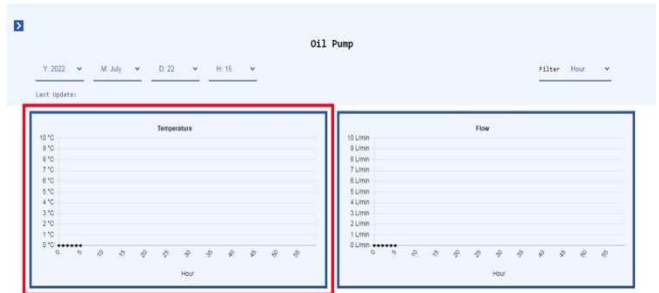

Fig. 8. Complete prototype of oil well monitoring system with process flow

III. RESULTS AND DISCUSSION

The results of the design of an oil well monitoring tool with the Internet of Things are as shown in figure 7 with the complete circulation system for testing in various scenarios as actual on the field. Testing of the temperature sensor will be tested with four tests, the first test is by heating the pipe using wax as a heat generator and the second test turning off the heater and letting the temperature or temperature of the oil drop, and the third and fourth tests are the same as the first test, only the test is not too hot so that there is the resulting difference.

According to figure 9, it can be seen that the sensor is attached to the frame. The temperature sensor (red point) is located before and after the pump engine, the flowmeter using a transducer (blue point) is located after the pump engine, and the faucet (orange point) is located before and after the pump engine. Please note, when oil is sucked in by the pump, the tank is considered an oil well and when it has passed through the pump, the tank is considered a gathering station. The process of oil flow in this prototype is that the Oil pump (pump engine) will suck oil from the oil well (tank) so that the oil flows through the oil pump and then the oil will continue to flow until it enters the gathering station (tank). Figure 8 shows an interface of the oil well monitoring system



for the temperature and flowrate measurement.

(a)

(b)

Fig. 9. Sample of graphs as display in monitoring system

Based on this process, the function of the first temperature sensor is to check the temperature of the oil before it is mined, the value of this sensor is only for testing the tool and the oil itself. The value that will be taken for monitoring is the value of the second temperature sensor, the sensor located after passing the oil pump. The function of the flowmeter sensor is to take the flow rate value of the oil that flows after passing

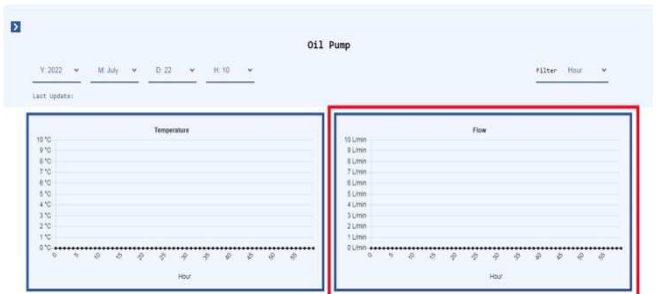

through the pump engine, and the faucet function to test the flow rate value when there is an obstacle. Then finally, the results of the oil well monitoring web design are shown below. The results of the temperature sensor test will be displayed in graphical form in a monitoring web application. The graphic display can be seen in the image as shown in figure 10 (a), (b), and (c) for scenarios of temperature.

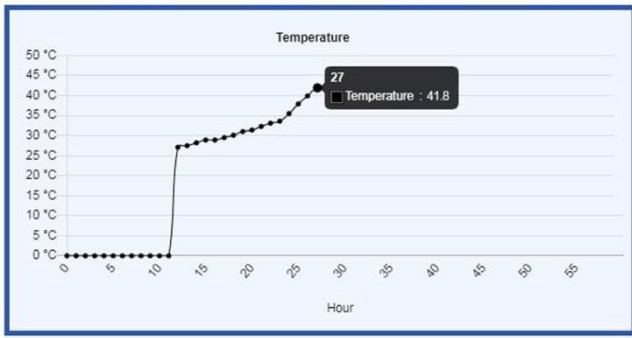

(a)

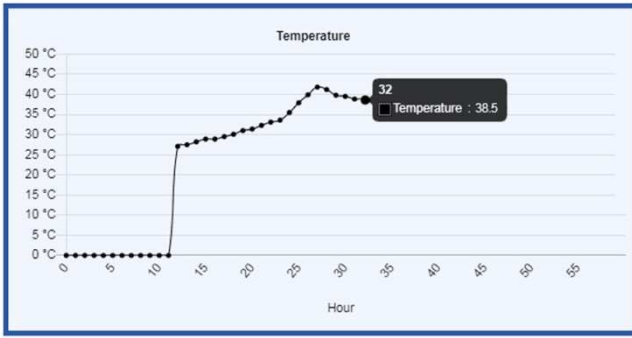

(b)

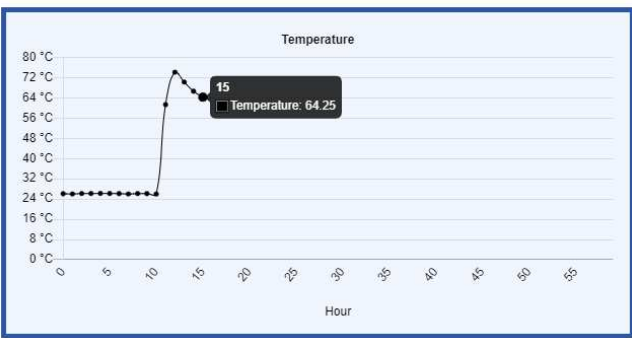

(c)

Fig. 10. Monitoring of oil well temperature in various scenarios (a) temperature 41.8 (b) temperature 38.5 degree (c) temperature 64.25 degree

While the flow rate sensor of the oil well and distribution pipe to the GS is measured in single line flow, the process is to monitor and retrieve sample data flow with duration every minute. Figure 11 (a), (b), and (c) shows a display of the measurement of flowrate in a pipe which is 0.23, 8.43, and 0.52 liters/minute, for the oil well monitoring system. This standard in the prototype unit is in unit liters/minute but in the actual field, the unit may be high liters/second or in oil barrels. The results of measurement flowrate to check and in actual situation to confirmation of the oil well is working fine to produce oil or the oil pump is working to supply oil to GS. Oil flow rate in a pipeline has an impact and indicator of the oil production, the normal flowrate has standard and may be different in every well, by the record and check the normality the production or failure of a well identified by the

monitoring system. Current status of parameters be able to monitor in a prototype are temperature and flow rate as shows in figure 10 and 11. While the other parameters such as API, Viscosity, and pressure of crude oil in the pipeline still under conducting the research and will added to the prototype system once completed.

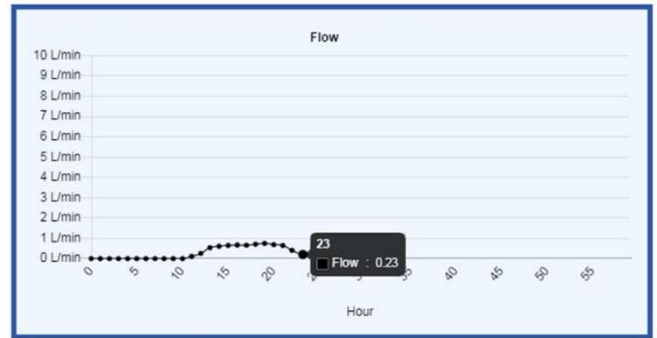

(a)

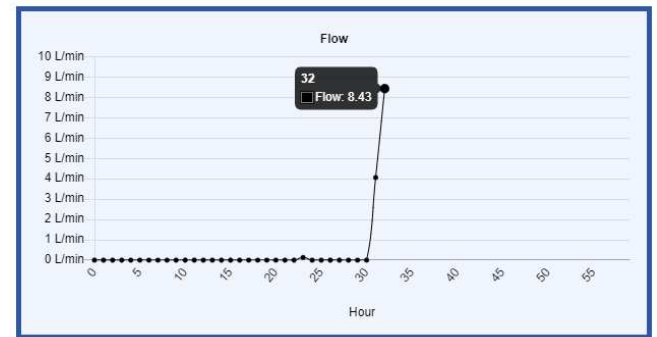

(b)

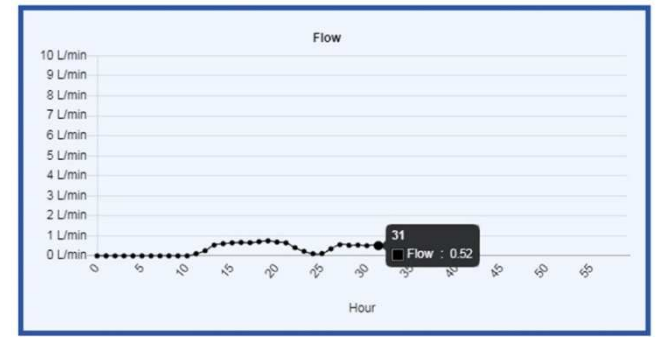

(c)

Fig. 11. Monitoring system of pipeline flowrate in an oil well (a) 0.23 (b) 8.43 (c) 0.53 liters/minute

IV. CONCLUSION

This research aims to monitor oil well status and equipment installed, the processes of designing, manufacturing, testing, and discussing oil well monitoring tools, it can be concluded several things such as an IoT-based oil well monitoring prototype was made using a Raspberry Pi 4 microcontroller with the help of a TUF-2000M flowrate sensor and a temperature sensor connected to a Web server. The process

of monitoring temperature and flowmeter using the Raspberry Pi 4 as a bridge between the TUF-2000M sensor and the Web server. Data from the flowrate and temperature sensors are sent using the request post technique and successfully display by the web system. The future development of the system is to do parallel monitoring for numbers of oil well that achieve real-time monitoring concurrently to all well.

ACKNOWLEDGEMENT

We would like to express our gratitude to the Ministry of Education, Culture, Research and Technology of Indonesia for funding the research, Universiti Teknologi Malaysia, and Universitas Islam Riau, Indonesia for research facilities as matching grant collaboration.

REFERENCES

- [1] Kesoema, Widhowati., Sulistiyani, Harmin., "Studi Literatur Alternatif Penanganan Tumpahan Minyak Mentah Menggunakan Bacillus subtilis dan Pseudomonas putida (Studi Kasus: Tumpahan Minyak Mentah Sumur YYA-1)", *Jurnal Teknik ITS*, Vol.9, 2020.
- [2] Mustaghfirin, "Proses Produksi Migas, Kementerian Pendidikan dan Kebudayaan", 2013.
- [3] D. Wang, R. He, J. Han, M. Fattouche and F. M. Ghannouchi, "Sensor network-based oilwell health monitoring and intelligent control", *IEEE Sensors J.*, vol. 12, no. 5, pp. 1326-1339, May 2012.
- [4] C. Tan, N. N. Wang, and F. Dong, "Oil-water two-phase flow pattern analysis with ERT based measurement and multivariate maximum Lyapunov exponent," *J. Cent. South Univ.*, vol. 23, no. 1, pp. 240-248, Jan. 2016, doi: 10.1007/s11771-016-3067-3.
- [5] E. A. Kadir, A. Efendi, and S. L. Rosa, "Application of LoRa WAN Sensor and IoT for Environmental Monitoring in Riau Province Indonesia," in 2018 5th International Conference on Electrical Engineering, Computer Science and Informatics (EECSI), 16-18 Oct. 2018 2018, pp. 281-285, doi: 10.1109/EECSI.2018.8752830.
- [6] G. Yang, Z. Ma, W. Xu, X. Huang and J. Zhou, "The development of drilling engineering monitoring system using wireless sensor networks", *Przegląd Elektrotech.*, vol. 89, no. 1, pp. 37-40, 2013.
- [7] E. A. Kadir, S. M. Shamsuddin, S. Hasan, and S. L. Rosa, "Wireless monitoring for big data center server room and equipments," in 2015 International Conference on Science in Information Technology (ICSITech), 27-28 Oct. 2015 2015, pp. 187-191, doi: 10.1109/ICSITech.2015.7407801.
- [8] M. M. F. Figueiredo, J. L. Goncalves, A. M. V. Nakashima, A. M. F. Fileti, and R. D. M. Carvalho, "The use of an ultrasonic technique and neural networks for identification of the flow pattern and measurement of the gas volume fraction in multiphase flows," *Experiment. Thermal Fluid Sci.*, vol. 70, pp. 29-50, 2016.
- [9] E. A. Kadir, H. Irie, S. L. Rosa, B. Saad, S. K. A. Rahim, and M. Othman, "Remote Monitoring of River Water Pollution Using Multiple Sensor System of WSNs and IoT," in *Sensor Networks and Signal Processing*, Singapore, S.-L. Peng, M. N. Favorskaya, and H.-C. Chao, Eds., 2021// 2021: Springer Singapore, pp. 99-113.
- [10] H. J. Park, Y. Tasaka, and Y. Murai, "Ultrasonic pulse echography for bubbles traveling in the proximity of a wall," *Meas. Sci. Technol.*, vol. 26, no. 12, p. 125301, 2015.
- [11] C. Zhao, G. Wu, and Y. Li, "Measurement of water content of oil-water two-phase flows using dual-frequency microwave method in combination with deep neural network," *Measurement*, vol. 131, pp. 92-99, Jan. 2019, doi: 10.1016/j.measurement.2018.08.028.
- [12] E. A. Kadir, H. Irie, and S. L. Rosa, "Modeling of Wireless Sensor Networks for Detection Land and Forest Fire Hotspot," in 2019 International Conference on Electronics, Information, and Communication (ICEIC), 22-25 Jan. 2019 2019, pp. 1-5, doi: 10.23919/ELINFOCOM.2019.8706364.
- [13] P. Angeli and G. F. Hewitt, "Flow structure in horizontal oil-water flow," *Int. J. Multiphase Flow*, vol. 26, pp. 1117-1140, Jul. 2000, doi: 10.1016/S0301-9322(99)00081-6.
- [14] E. A. Kadir, M. Othman, and S. L. Rosa, "Smart Sensor System for Detection and Forecasting Forest Fire Hotspot in Riau Province Indonesia," in 2021 International Congress of Advanced Technology and Engineering (ICOTEN), 4-5 July 2021 2021, pp. 1-6, doi: 10.1109/ICOTEN52080.2021.9493535.
- [15] T. Nakashima, T. Shiratori, Y. Murai, Y. Tasaka, Y. Takeda, and E. J. Windhab, "Viscoelastic responses of flow driven by a permeable disk investigated by ultrasound velocity profiling," *Flow Meas. Instrument.*, vol. 48, pp. 97-103, Apr. 2016.
- [16] E. A. Kadir, S. L. Rosa, and R. A. Ramadhan, "Detection of Forest Fire Used Multi Sensors System for Peatland Area in Riau Province," in 6th International Conference on Industrial Mechanical Electrical Chemical Engineering 2020, Surakarta, Indonesia, W. Sutopo, Ed., 2020: AIP Conference Proceedings.

ICIC APTIKOM

International Conference on
Informatics and Computing **2022**

Technical Sponsor:



CERTIFICATE OF PARTICIPATION



This is to certify that

Evizal Abdul Kadir, Muslim Abdurrahman, Sharul Kamal Abdul Rahim, Agus Arsad, Sri Listia Rosa, dan Apri Siswanto

has written the Paper titled

Oil Well Monitoring System Based on IoT Technology and Machine Learning

*at the 7th International Conference on Informatics and Computing (ICIC 2022)
held between 08-09 December 2022 at Bali*

General Chair of APTIKOM

APTIKOM
ASOSIASI PENDIDIKAN TINGGI INFORMATIKA DAN KOMPUTER
Zainal A. Hasibuan

Organising Chair of ICIC 2022

ICIC
2022
Yusuf Durachman

disponsori oleh:

