



UNIVERSITI
TEKNOLOGI
PETRONAS

CERTIFICATE

_____ of presenter _____

This is to certify that

DR DEDIKARNI

has participated in

**INTERNATIONAL SEMINAR ON UTP - UIR
MATCHING GRANT PROGRESS REPORT 2019**

on

11TH & 12TH MARCH 2019

at

UNIVERSITI TEKNOLOGI PETRONAS

organized by

**FUNDAMENTAL & APPLIED SCIENCES
DEPARTMENT (FASD)**

ASSOC. PROF. DR. HANITA BT DAUD
Chair of Fundamental and Applied Sciences Department (FASD)
Universiti Teknologi PETRONAS



Effect of various repetition coating and thickness of YSB electrolyte on the electrochemical performance of the single button cell solid oxide fuel cell

Dedikarni Panuh ^{a,c*}, Dody Yulianto ^a, M. F. Shukur ^b, Andanastuti Muchtar ^a,

^aDepartment of Mechanical Engineering, Faculty of Engineering, Universitas Islam Riau, Indonesia

^bFundamental and Applied Sciences Department Universiti Teknologi Petronas, Seri Iskandar, Malaysia

^cFuel Cell Institute, Universiti Kebangsaan Malaysia, 43600 UKM Bangi, Selangor, Malaysia

*Corresponding Author: dedikarni@eng.uir.ac.id

ABSTRACT

Reducing the operating temperature and optimization design while maintaining high cell performance is the primary consideration in designing current SOFCs. The effect of the electrolyte YSB thickness on the electrochemical performance of the single cell was measured from 500–650°C was studied in detail. Cell performance testing was performed using impedance for electrochemical characterization and single-cell capability testing. The YSB electrolyte coated on the NiO–SDC | SDC substrates was deposited as a thin film with varying thicknesses of 1.5, 3.5, 5.5, and 7.5 µm after 1, 2, 3, and 4 applications of coatings, respectively, at a sintering temperature of 800°C for two h. These findings confirmed that the number of layers was proportional to the thickness of the YSB electrolyte. The results indicated that the bilayer electrolyte system of $Y_{0.25}Bi_{0.75}O_{1.5}/Sm_{0.2}Ce_{0.8}O_{1.90}$ with three applications of coating at 650°C exhibited optimum current and power densities of 228 mA/cm² and 82 mW/cm², respectively. The interfacial polarization cells achieved a low total resistance (0.55 Ωcm²) and a high open circuit potential (1.092 V) after three coating applications with 5–6 µm thickness at 600°C. This study produced a single button cell system with a total deficient cell interfacial resistance compared to the previous studies on intermediate and low-temperature SOFCs.

Key Words: SOFC, Bilayer Electrolyte, SDC, YSB.

Introduction

High operating temperature is one of the main barriers to the wide-scale adoption of solid oxide fuel cell (SOFC) technology [1]. Therefore, most research focused on developing low-intermediate temperature SOFC operating at around range temperature 500-600 [2]. To achieve low-intermediate temperatures, several from the viewpoint of new materials, novel processes, and unique architectures must be re-examined [3].

Recently most research and development activities on SOFC are mainly focused on the commercially viable SOFC manufacturing technology with high electrochemical performance, the transformation of stack design, and cost-effective process. In fabrications, p has been proposed and developed for SOFC. Various are available for depositing films on dense or porous substrates based on ceramic powder techniques or chemical and physical processes. These methods include electrochemical vapor deposition, chemical vapor deposition, physical vapor deposition (radio frequency and magnetron sputtering), laser ablation, plasma spraying, and depositing techniques [4][5].

Although the methods mentioned above are well established, the investment cost for the apparatus is higher than those used in the dip coating method. Dip coating is expected to produce a satisfactory surface condition in the fabrication of YSB bilayered composite film electrolyte on the SDC electrolyte because the thickness of the electrolyte substrate can be easily controlled through the number of dip coatings. This technique is the simplest and the most appropriate method for preparing films with large surface areas [6]. Furthermore, dip coating is inexpensive and more suitable for mass production, even in multi-layer cells.

Electrolyte thickness is essential and must be considered because surface morphology has a vital function in the physical and chemical properties of the bilayer electrolyte [7][8]. However, details of the optimum thickness and electrochemical properties of YSB composite electrolytes on SDC/YSB bilayered electrolytes are scarce. This study aims to determine the influence of SDC/YSB bilayered combined electrolyte thickness on the interfacial polarization resistance and electrochemical performance of single SOFC cells with SDC/YSB as a bilayered electrolyte, Ag-YSB composite as cathode and NiO-SDC as an anode.

Experiment Procedure

2.1 Materials and specimen preparation

Commercial material available yttrium oxide (99.999 wt%) and bismuth (III) oxide (99.999 wt%, Sigma Aldrich Sdn. Bhd) was mixed at a molar ratio 1 of : 3. The powder and Zirconia ball (Fritsch Pulverisette 6) in ethanol was combined with mechanical mill method for 24 h, and then calcined in air at 750 °C. This-gel practice prepares three-element SDC powder with (Ce_{0.8}sol-gel_{1.9}) d [9].

NiO, Nickel (II) Oxide (99.8 wt%, Sigma Aldrich Sdn. Bhd), and SDC powder were mixed at a weight ratio of 60:40 and were prepared by ball milling in ethanol for 24 h. NiO-SDC powers were mixed with zirconia ball medium, dried in an oven at 80 °C for 12 h, and thoroughly ground. The dried powders were then heated and called at 1100°C for 5 hours to obtain NiO-SDC composite powder.

To prepare the Ag-YSB cathode slurry, silver (I) oxide (99.8 wt%, Sigma Aldrich Sdn. Bhd) and YSB were added at a weight ratio of 50:50. The α -terpineol, di-n-butyl phthalate (Merck Sdn. Bhd), and polyvinyl butyral (PVB) (Sigma) as organics binder were mixed at a volume ratio 3: 1: 2. The organics binder was ma mixture with agate mortar in ethanol as a dispersing medium for 30 min.

2.2 Characterization

The microstructure of single button cells SOFC samples was observed using field emission scanning electron microscopy (FESEM), and the formation of different phases by the Ag-YSB, YSB, SDC, and NiO/SDC system during the coating of bilayer electrolyte films was investigated using X-ray diffraction (XRD) and electrochemical impedance spectroscopy (EIS). The temperature and mass loss with phase transformation was determined by gravimetric analysis and differential scanning calorimetry (TGA and DSC Jupiter 449F3) from 30 °C to 1200 °C. The phase of the cathode was analyzed using XRD (semen D-500) with Cu K α at a 2 θ range from an angle of 20° to 80°, and the Rietveld method using the EVA software were obtained pattern refinements. The morphology and grain size of the composite cathode pellets was observed using a Scanning electron microscope (Zeiss EVA MA10) with 15 XK magnification.

2.3 Button single-cell fabrication, performance, and electrochemical measurement

The NiO-SDC anode and the SDC electrolyte pellets were co-pressing by cold pressing. The pellet was used as a substrate or half-cell (25 mm diameter and sintered at 1400°C for five h). The NiO-SDC anode and SDC/YSB bilayered electrolyte (half Cell) were coated with Ag-YSB cathode slurry using SPM. The Ag_2O_3 and YSB powder as composite cathode and organic binder were mixed by SPM, then deposited onto the substrate surface. The slurry containing the composite and organic binder desired to make the solid deposited film by a chemical reaction method. And then, the influence of the coating process on thickness layers was investigated with four times repetitions. By sintering, the composite cathode fabricates at 800 °C for two h in air. The complete single SOFC button cell system became the end product system. The final configuration button single cell (NiO-SDC/SDC/YSB/Ag-YSB) based on substrate SDC/YSB as a bilayer electrolyte is shown in fig 1.

The half cell with Ag-YSB composite cathode was measured electrochemical performance (interfacial polarization resistance, R_p) using EIS Autolab Nova 1.8 Model PGSTAT302N). The impression of repetition of coating and temperature on cell performance was assessed using impedance spectroscopy. This test has been widely used to determine the achievements of solid oxide fuel cells involving more complex curvature (arc) with various processes and materials used in making single cells. Different cell manufacturing processes have contributed to a more complex impedance spectrum. The impedance spectrum has been used to separate and identify the bulk interfacial polarization resistance (R_p Total, Report), the constant phase element (CPE), and the interfacial polarization resistance (R_p) in the range of 0.01 Hz to 10 kHz.

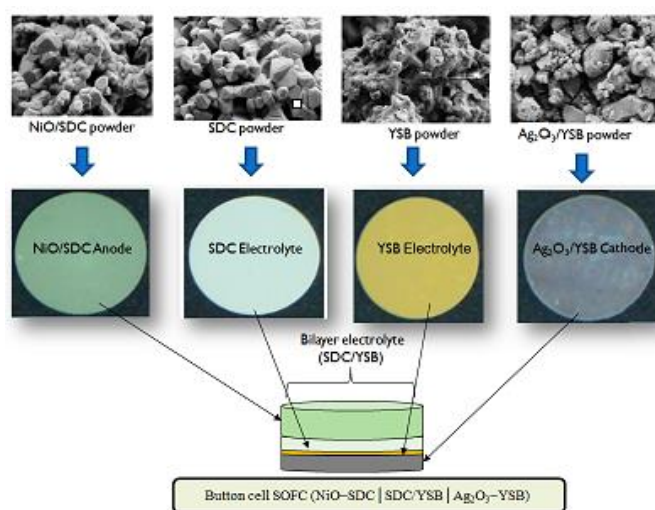

Fig. 1 A schematic configuration of NiO-SDC/SDC/YSB/Ag-YSB as a button

single cell SOFC.

4. Result and discussion

4.1 Button Single-Cell Performance Analysis

The performance of cells is shown in Figure 2, with hydrogen and pure oxygen as oxides. Performance measurements were performed at operating temperatures of 600°C.

Studies on the effect of YSB electrolyte thickness on the surface of the SDC electrolyte in the form of NiO–SDC | SDC/YSB | Ag₂O₃–YSB single cell. NiO–SDC anode is a supporting substrate, and Ag₂O₃–YSB is a cathode. The current density and voltage (I-V) performance on YSB thickness was conducted with NiO–SDC | SDC/YSB | Ag₂O₃–YSB single-cell anode support. YSB electrolyte performance testing can be performed when a cell is designed with SDC electrolyte on the anode surface, and YSB is coated on the cathode surface to stabilize YSB and SDC under oxygen reduction (P_{O_2}) conditions [10][11].

The results of the performance tests of open-circuit potential (OCP), current density (I), and power density (P) of cells at 600°C are shown in Figure 2 (a). The maximum power density of a single cell NiO–SDC | SDC/YSB | Ag₂O₃–YSB with a single YSB electrolyte coating was 66.1 mW/cm², and the maximum current density was 188 mA/cm² at 600°C.

The result of the measurement of the maximum power density in the second YSB electrolyte coating with a yield of 72 mW/cm² and the maximum current thickness was 212.2 mA/cm² as shown in Figure 2 (b). Figure 2 (c) shows the results of the measurement of maximum power density during the third YSB electrolyte coating of 82 mW/cm² and maximum current thickness with yields of 225.3 mA/cm². Figure 2 (d) shows the results of measuring the maximum power density at four times the YSB electrolyte coating is 80 mW/cm² and the maximum current density is 218.7 mA/cm². Increased OCP (Volt), I (mA/cm²), and P (mW/cm²) values from one coating to the fourth coating, as shown in Figure 2. The maximum power density was obtained at an operating temperature of 600°C with an average electrolyte thickness (YSB) of 5.5 μm, which was the third time. Subsequently, OCP, I-V, power density, and ty values began declining during the fourth coating. In parallel with the FESEM thickness test, four coating times produced YSB electrolyte thickness at an average thickness of 7.5 μm. The effect of increasing the number of coatings on the OCP value, current density, and single-cell power developed is shown in Figure 2. The maximum voltage value, power density, and present are obtained by optimizing the YSB electrolyte thickness value. The increase in V

(Volt), I (mA/cm^2), and P (mW/cm^2) values of the YSB electrolyte thickness change is evidence that YSB electrolytes have successfully inhibited electrolyte conductivity (SDC) since the reduction of Ce^{4+} to Ce^{3+} did not occur in the interface area so that it does not affect cell performance. Increased voltage, current, and power values are also observed in ESB/GDC double-layer thin film electrolytes [12]. Ahn et al. (2009) [12] reported that ESB thin film electrolytes were produced on the surface of GDC electrolytes using a physical vapor deposition (PVD) method. Ahn et al. (2009) also reported that the performance of single button cells with double-layer electrolyte thin film (ESB/GDC) film ($\sim 10 / \sim 4 \mu\text{m}$) resulted in an OCP increase of 0.72 to 0.77 V.

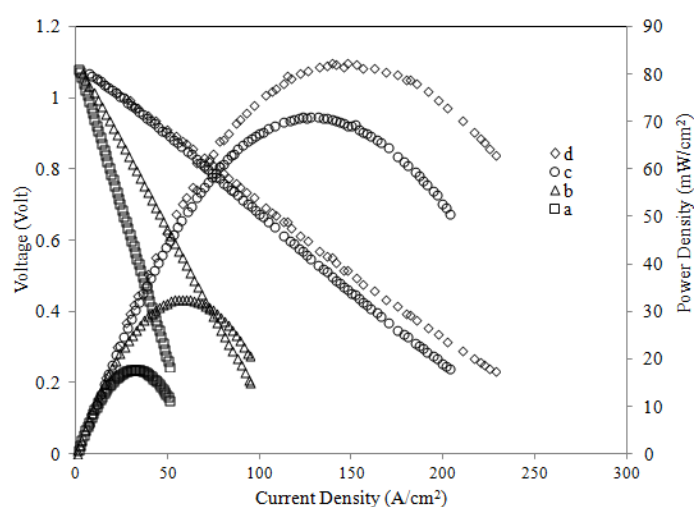

Figure 2 Current (I) –Voltage (V) performance test with (a) one, (b) two, (c) three, (d) four YSB coating times the bilayer electrolyte

The average OCP for various repeats of YSB electrolyte coating on the surface of the SDC electrolyte is shown in Figure 3. OCP values in one coating up to four times coating are 1.068 V, 1.072 V, 1.092 V, and 1.084 V. OCP, I-V values, and optimum power density are in the third coating with moderate operating temperature ($600 \text{ }^\circ\text{C}$) with OCP value of 1.092 V, a current density of $0.23 \text{ mA}/\text{cm}^2$ and a power density of $82 \text{ mW}/\text{cm}^2$. Increasing the number of coatings up to three repetitions increased the OCP value to 1.092 V. The optimum coating thickness was performed three times to repeat the YSB electrolyte coating on the surface of the SDC electrolyte and produced a YSB electrolyte thickness of $5.5 \mu\text{m}$. Increased OCP value, up to 1.092 V, current density $0.23 \text{ mA}/\text{cm}^2$ and power density $82 \text{ mW}/\text{cm}^2$. The SDC, in this case, produced an oxygen vacancy in which three O^{2-} ions replaced four O^2 ions. The emptiness

of the oxygen site has led to the movement of electrons and the increase in ion flow in the electrolyte. SDC is a highly ionic conductivity material with a readily available oxygen atom in which the movement causes ion flow.

Optimum coating and thickness have resulted in maximum OCP value. However, the fourth coating decreased the OCP value to 1.084 V. Increasing the thickness to 7.5 μm in the fourth coating decreased the OCP value. This condition occurs when the YSB electrolyte thickness exceeds the optimum thickness, and the YSB electrolyte begins to decompose. In SDC electrolytes, Ce^{4+} to Ce^{3+} electrons were decreased at low oxygen partial pressure and mixing of ion and electron conductance. Mixing electrons and ions with high-performance electrolytes has led to short circuits and decreased cell performance. YSB electrolyte thin films can prevent the cell from degrading and inhibiting electrolyte conductance across the electrolyte. YSB electrolytes are used to suppress electron conductivity from the substrate, and YSB thin layers are also used to produce high ion conductance. The SDC layer acts as a support for the YSB to be stable and stable [13].

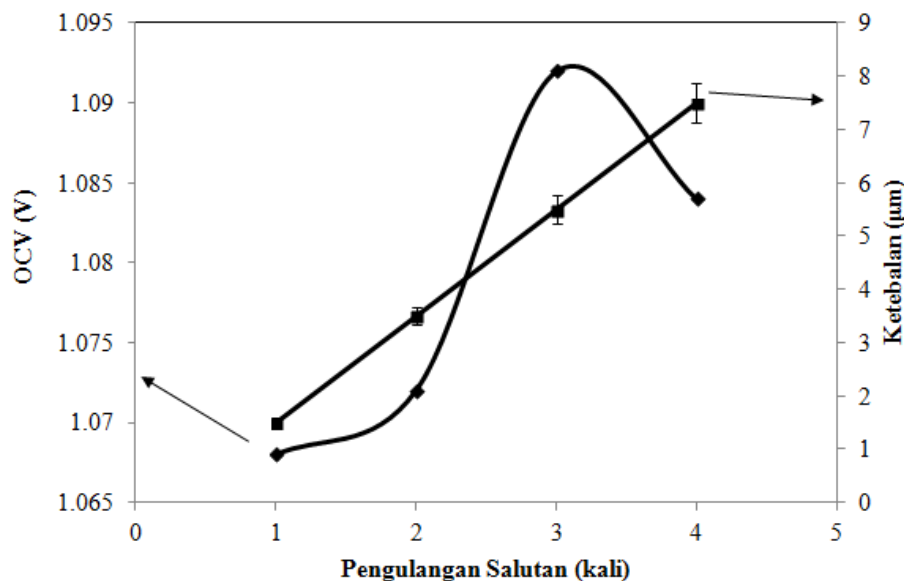

Figure 3 Average OCP for various repetition coating and thickness of YSB electrolyte on SDC electrolyte surface

Bilayer electrolyte analysis for YSB / SDC has also been investigated by Virkar (1991) [14], Huang et al. (2008) [15], and Zhang et al. (2011) [13]. Oxygen partial pressure (P_{O_2}) values of two electrolytes were determined by the electrolyte thickness ratio and ion and electron conductivity of both electrolytes. The use of thin layers of SDC $<10 \mu\text{m}$ and YSB $<6 \mu\text{m}$ gave a low resistance drop and provided control to the surface for no degradation. This is because the oxygen partial pressure (P_{O_2}) interfacial with the SDC is further. The thickness of

YSB $<6 \mu\text{m}$ and SDC $<10 \mu\text{m}$ protected the electrolyte in bulk. However, if a very thick YSB film is found, it can increase the electrolyte resistance and cause a decrease in ion conductivity. YSB electrolyte films that are too thick also make YSB easy to decompose. This is due to the oxygen partial pressure (P_{O_2}) and the rising temperature of the environment.

4.2 Impedance spectroscopy analysis

Four impedance spectra with one repetition of the coating to four times the layer, as shown in Figure 4. Each repetition of the coating consists of three overlapping arcs. Figure 4 (a) shows the impedance spectrum with one coating. Three turns in the figure with a larger diameter than the YSB electrolyte as a second coating. This condition indicates a more significant overall coating than the second YSB electrolyte coating. Figure 4 (b) shows the impedance spectrum with twice the layer. The figure showed three arcs with smaller diameters than the YSB electrolyte coating for the first repetition and more significant than the third coating.

This phenomenon shows that the overall resistance in the second coating is smaller than the one coating, and the thick one is the YSB electrolyte coating a third time. Figure 4 (c) shows the impedance spectrum with three times the layer. The figure showed three half rounds with smaller diameters than all YSB electrolyte coatings. This condition applies because three times, the coating is sufficient to cover the entire surface of the SDC electrolyte with the optimum coating thickness and gives the lowest overall resistance; Rajah 4 (d) shows the impedance spectrum with four times the YSB electrolyte coating on the SDC surface. Impedance spectrum at one time coating so that four times the coating exhibited a decrease in half size and increased initially at the fourth time coating. This phenomenon holds because the increase in layer gives the impression of decreasing the overall barrier of cells so that optimum thickness is achieved. This condition is indicated by the decrease in size halfway around between the third coating is more closely matched so that it overlaps on the bulk resistance (R_b) and the electrode resistance (R_e), and the repetition of the layer has reached the optimum thickness three times to produce a decrease in minimum resistance. However, the overall resistance has reincreased for the fourth time. This condition is shown by the enlargement of half the size of the electrode resistance (R_e).

The first arc for a real axis at high frequencies is the ohm resistance (R_s) contributed by the wire and cell resistance. In this study, the platinum mode is connected to the outer circuit to determine the value of resistance, OCP, power, and current density. Interfacial polarization resistance (R_p), R_p is the bulk resistance (R_{bulk} , R_b) + grain boundary resistance (R_{grain}),

R_g) + resistance electrode ($R_{\text{elektrode}}$, R_e), and the total polarization resistance (R_{report}) is $R_s + R_p$. All these resistance are known to use Autolab with Nova 1.5 software in the form of equal spectra and circuits to obtain the value of each coated resistance.

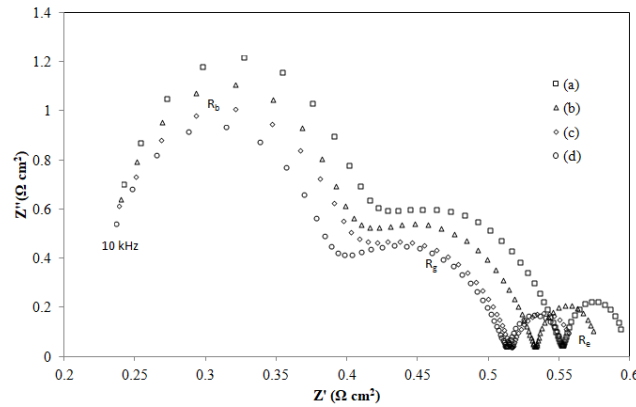

Figure 4 The impedance spectrum shows the variety of coating repetitions: (a) once, (b) twice, (c) three times, and (d) four times.

The impedance spectral equivalent circuit of SOFC single button cells with YSB electrolyte thickness at one time repeated coating up to four times with coating resistance total (R_{report}), $0.6 \Omega\text{cm}^2$, $0.56 \Omega\text{cm}^2$, $0.55 \Omega\text{cm}^2$ and $0.58 \Omega\text{cm}^2$ and interfacial resistance (R_p) $0.37 \Omega\text{cm}^2$, $0.34 \Omega\text{cm}^2$, $0.33 \Omega\text{cm}^2$, $0.35 \Omega\text{cm}^2$ as shown in Figure 5 and 6. However, different electrolyte layer thicknesses do not have a significant impact on the ohm resistance (R_s) values of $0.228 \Omega\text{cm}^2$, $0.225 \Omega\text{cm}^2$, $0.224 \Omega\text{cm}^2$ and $0.227 \Omega\text{cm}^2$ as the ohm resistance value is related to the interconnect wire between the cell and the outer circuit. In this study, the value of the ohm resistance has little effect on the overall resistance and can be ignored because the same connection wire is used every time a test is used. Therefore, modification of the ohm resistance is unnecessary as it does not significantly impact the system as a whole.

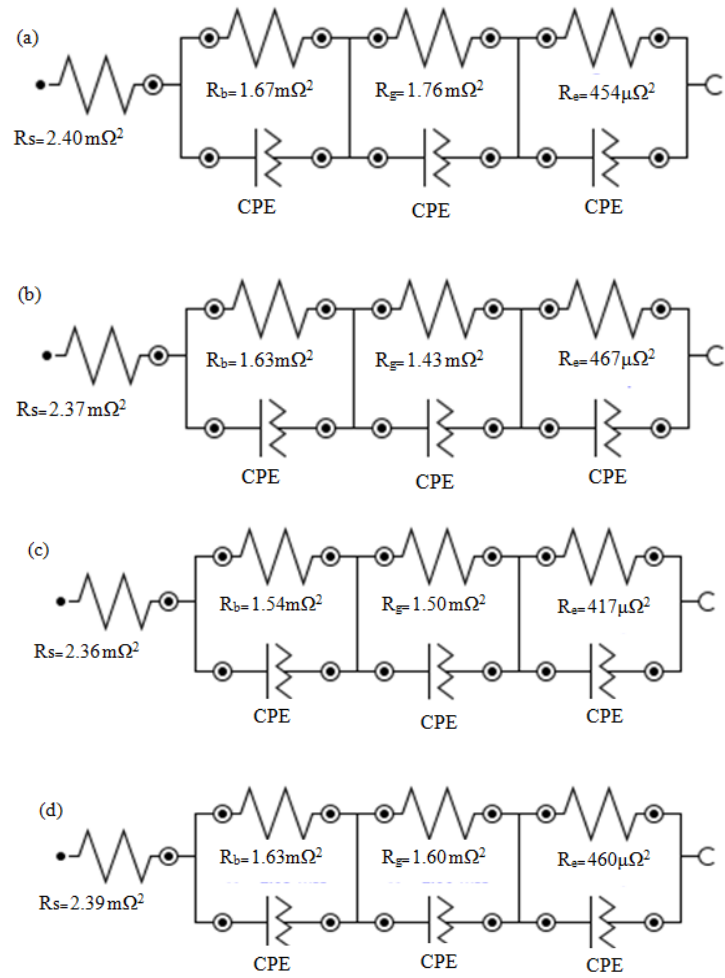

Figure 5 Impedance spectrum equivalent circuits based on various coating repetitions: (a) once, (b) twice, (c) three times, and (d) four times.

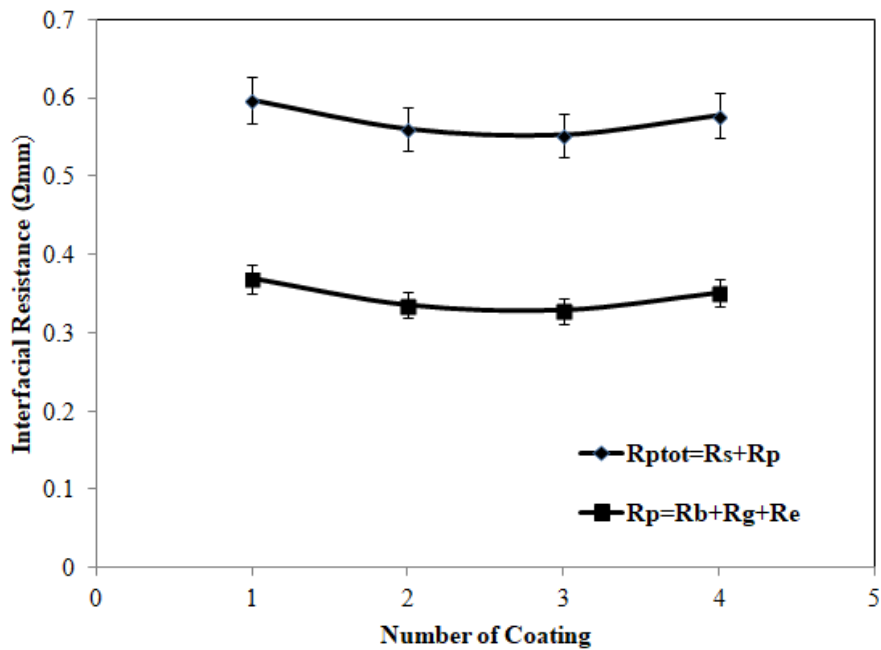

Figure 6 Total interfacial polarization resistance ($R_{p_{tot}}$) and bulk interface polarization resistance (R_p) at various coating repetitions: (a) once, (b) twice, (c) three times, and (d) four times.

The addition of the YSB electrolyte coating up to 4 times reduced the interfacial resistance value (R_p) contributed by the grain resistance (Rebound, R_g) and the electrode resistance (Relectrode, R_e). YSB electrolyte coating produced a $0.60 \Omega\text{cm}^2$ polishing interfacial and dropped to $0.55 \Omega\text{cm}^2$ on the third coating. The third coating with a thickness of $5.5 \mu\text{m}$ gave the lowest R_p value, and the interface resistance increased again to $0.58 \Omega\text{cm}^2$ on the fourth coating. The addition of YSB electrolyte coating on the surface of the SDC electrolyte affected the interfacial polarization resistance (R_p). The three-coating addition of YSB electrolyte coating reduced the opposition to a minimum because the third coating successfully thinned the entire surface of the SDC electrolyte and prevented the flow of electrons from the SDC electrolyte ideally. Two-layer electrolyte analysis for YSB/SDC was also studied by Virkar (1991)[14], Huang et al. (2008)[15], and Zhang et al. (2011) [13].

The oxygen partial pressure (P_{O_2}) of two electrolytes is determined by the ratio of electrolyte thickness and ion and electron conductivity of both electrolytes. The thickness of YSB $< 2 \mu\text{m}$ protected the electrolyte in bulk, and the CeO_3/YSB thickness ratio was large. If the oxygen partial pressure (P_{O_2}) interface is too close to the surface and the YSB film is insufficient to cover the ceria surface, then there is a decrease in the shear due to exposure to P_{O_2} . The use of a thin layer of fiber ($< 10 \mu\text{m}$) with a YSB thin layer of $< 6 \mu\text{m}$ gave a decreasing resistance and showed the control of the ceria no reduction, as the oxygen partial pressure (P_{O_2}) interfacial was closer to the fuel. However, adding up to four times the coating exceeds the maximum threshold, resulting in an increase in the polarization resistance of the interfacial. Excessive growth in the number of layers can also prevent the flow of electrons and ion conductance from the electrolyte to the cathode.

This decrease in the interfacial polarization resistance is due to the maximum ability of the YSB electrolyte to inhibit the conductivity of the SDC electrons across the YSB electrolyte. It is expected to increase the conductivity of the oxygen ions across the YSB electrolyte. The decreased R_p was also due to the compatibility between the YSB electrolyte and the Ag_2O_3 -YSB cathode. Using the same electrolyte and electrode materials is expected to facilitate the conductivity of oxygen ions from electrolytes with YSB material and cathode composites with YSB and Ag_2O_3 mixtures. According to the report of Zhang et al. (2010)[16] and Kenjo and

Kanehira (2002)[17], this phenomenon also occurs in LSM–YSB materials and YSB electrolytes. The decrease in R_p is due to the increase in oxygen ion conductance and chemical compatibility between the cathode material (LSM–YSB) and the YSB electrolyte. Chemical compatibility between cathode and electrolyte occurs when electrolytes and cathodes are based on the same material until the manufacture and operation of a single button cell do not occur, cracking and separation of each component due to different thermal expansion. Low and high-frequency intervals for interfacial polarization resistance (R_p) are also contributed by the anode and cathode [18]. In this study, the high frequency (1 kHz) and low (0.1 Hz) shortcuts occur on the Z' axis approaching $0.4 \Omega\text{cm}^2$.

The results of this study are compared to several previous studies with SDC/YSB bilayer-layer electrolytes at 0.5 mm SDC thickness and $5.5 \mu\text{m}$ YSB and $\text{Ag}_2\text{O}_3/\text{YSB}$ cathode material with an operating temperature of 600°C as shown in Table 4.2. This study using YSB electrolyte materials yielded higher OCP results than previous research. Previous research reports by Wachsman et al. (1992) [19] on GDC/ESB bilayer-layer electrolytes at $0.9 \mu\text{m}$ GDC thickness and 50-60 μm ESB thickness with Au cathode materials gave an OCP value of up to 0.901-0.977 V. This is due to the unstable ceria and the use of Au as a cathode material as a good electron conductor

Park and Wachsman (2006)[20] investigated the SDC/ESB bilayer layer electrolyte at $1.5 \mu\text{m}$ SDC thickness and nine μm ESB with Au cathode material, giving OCP value up to 0.783 V. And then, Park and Wachsman (2006) investigated the SDC/ESB bilayer layer electrolyte at thickness $1.5 \mu\text{m}$ SDC and 22 μm ESB with Ag/YSB cathode material gave an OCP value of up to 0.949 V. The increase in ESB electrolyte thickness on the SDC surface resulted in an increase in OCP value from 0.783-0.949 V. The OCP value increase occurred due to the ESB increasing ion conductivity and did not occur because the SDC backing electrolyte successfully prevented YSB from decomposition.

Leng and Chan (2006) [21] investigated the bilayer-layer GDC/YSB electrolyte at GDC thickness of $84 \mu\text{m}$ and YSB $6 \mu\text{m}$ with Pt cathode material giving an OCP value of up to 0.885 V. Zhang et al. (2010) [16] investigated the bilayer-layer SDC/YSB electrolyte at SDC 26 and $6 \mu\text{m}$ thickness with LSM / YSB cathode material giving OCP values up to 0.897 V and Zhang et al. (2011)[13] investigated the bilayer-electrolyte at GDC/YSB thickness with GDC thickness of $26 \mu\text{m}$ and YSB $6 \mu\text{m}$ with Ag/YSB cathode material giving OCP value of up to

0.887 V. OCP value increase occurred in the event of a decrease in the support electrolyte thickness. This is due to the reduction of the supporting electrolyte thickness, which increases the conductivity of the ion from the cathode to the electrolyte. However, the use of not match electrolyte cathode material reduced the OCP value from 0.897-0.887 V. This is due to electrolyte material that does not fit the cathode and causes both components to not optimally, thus reducing cell performance. Therefore, it can be concluded that the performance value differences from some previous studies were due to different material selection parameters, manufacturing methods, and coating thickness. Optimization of material selection parameters, manufacturing methods, and coating thickness also contributed to the increased OCP value.

4 CONCLUSIONS

The $Y_{0.25}Bi_{0.75}O_{1.5}$ electrolyte (YSB) was used to suppress the electron conductivity of the substrate, and the YSB thin layer (5.5 μm) was used to produce high conductivity in the electrolyte. The YSB thin film electrolyte coating on the surface of the SDC electrolyte prevented Ce_2O_3 from being exposed to partial oxygen pressure. Increased OCP value, up to 1.092 V, current density 0.23 mA/cm^2 and power density 82 mW/cm^2 . The SDC, in this case, produced an oxygen vacancy in which three O^{2-} replaced four O^2 ions. The emptiness of the oxygen site has led to the movement of electrons and the increase in ion flow in the electrolyte. The YSB with the $Y_{0.25}Bi_{0.75}O_{1.5}$ system prevented the ceria (Ce_2O_3) from degrading (Ce^{4+} to Ce^{3+}) and restricted the electrons' conductivity across the electrolyte. The thick (0.5 mm) SDC layer acts as a YSB support for more OCP and stability single button solid oxide fuel cell.

ACKNOWLEDGMENTS

The author acknowledges Universiti Petronas Malaysia, the Universitas Islam Riau, for the matching grand research sponsorship under Nomor: 468/Kontrak/LPM-UIR-9-2018 and 361/Kontrak/LPPM-UIR/4-2018.

REFERENCES

- [1] S. P. S. Badwal and K. Foger, "Solid Oxide Electrolyte," *Ceram. Int.*, vol. 8842, no. 95, pp. 257–265, 1996.
- [2] K. Eguchi, T. Setoguchi, T. Inoue, and H. Arai, "Electrical properties of ceria-based oxides and their application to solid oxide fuel cells," *Solid State Ionics*, 1992.
- [3] D. Yang *et al.*, "Low-temperature solid oxide fuel cells with pulsed laser deposited bi-

- layer electrolyte,” *J. Power Sources*, 2007.
- [4] Y. C. Yang, P. H. Wang, Y. T. Tsai, and H. C. Ong, “Influences of feedstock and plasma spraying parameters on the fabrication of tubular solid oxide fuel cell anodes,” *Ceram. Int.*, 2018.
- [5] L. S. Wang, C. X. Li, C. J. Li, and G. J. Yang, “Performance of La_{0.8}Sr_{0.2}Ga_{0.8}Mg_{0.2}O₃-based SOFCs with atmospheric plasma sprayed La-doped CeO₂ buffer layer,” *Electrochim. Acta*, 2018.
- [6] D. Panuh, A. Muchtar, N. Muhamad, E. H. Majlan, and W. R. W. Daud, “Fabrication of thin Ag-YSB composite cathode film for intermediate- temperature solid oxide fuel cells,” *Compos. Part B Eng.*, 2014.
- [7] T. Talebi, M. Haji, and B. Raissi, “Effect of sintering temperature on the microstructure, roughness and electrochemical impedance of electrophoretically deposited YSZ electrolyte for SOFCs,” in *International Journal of Hydrogen Energy*, 2010.
- [8] M. S. Djošić, V. B. Miskovic-Stankovic, and V. V. Srdić, “Electrophoretic deposition and thermal treatment of boehmite coatings on titanium,” *J. Serbian Chem. Soc.*, vol. 72, no. 3, pp. 275–287, 2007.
- [9] A. Bodén, J. Di, C. Lagergren, G. Lindbergh, and C. Y. Wang, “Conductivity of SDC and (Li/Na)₂CO₃ composite electrolytes in reducing and oxidizing atmospheres,” *J. Power Sources*, vol. 172, no. 2, pp. 520–529, 2007.
- [10] T. Takahashi, T. Esaka, and H. Iwahara, “Conduction in Bi₂O₃-based oxide ion conductor under low oxygen pressure. II. Determination of the partial electronic conductivity,” *J. Appl. Electrochem.*, vol. 7, no. 4, pp. 303–308, 1977.
- [11] N. Jiang, E. D. Wachsman, and S. H. Jung, “A higher conductivity Bi₂O₃-based electrolyte,” *Solid State Ionics*, vol. 150, no. 3–4, pp. 347–353, 2002.
- [12] J. S. Ahn *et al.*, “High-performance bilayered electrolyte intermediate temperature solid oxide fuel cells,” *Electrochem. Commun.*, vol. 11, no. 7, pp. 1504–1507, 2009.
- [13] L. Zhang, L. Li, F. Zhao, F. Chen, and C. Xia, “Sm_{0.2}Ce_{0.8}O_{1.9}/Y_{0.25}Bi_{0.75}O_{1.5} bilayered electrolytes for low-temperature SOFCs with Ag-Y_{0.25}Bi_{0.75}O_{1.5} composite cathodes,” *Solid State Ionics*, vol. 192, no. 1, pp. 557–560, 2011.
- [14] A. V. Virkar, “Theoretical analysis of solid oxide fuel cells with two-layer, composite electrolytes: Electrolyte stability,” *J. Electrochem. Soc.*, vol. 138, no. 5, pp. 1481–1487, 1991.
- [15] S. Huang, G. Zhou, and Y. Xie, “Electrochemical performances of Ag-

- (Bi₂O₃)_{0.75}(Y₂O₃)_{0.25} composite cathodes,” *J. Alloys Compd.*, vol. 464, no. 1–2, pp. 322–326, 2008.
- [16] L. Zhang, C. Xia, F. Zhao, and F. Chen, “Thin film ceria-bismuth bilayer electrolytes for intermediate temperature solid oxide fuel cells with La_{0.85}Sr_{0.15}MnO_{3-δ}-Y_{0.25}Bi_{0.75}O_{1.5} cathodes,” *Mater. Res. Bull.*, vol. 45, no. 5, pp. 603–608, 2010.
- [17] T. Kenjo and Y. Kanehira, “Influence of the local variation of the polarization resistance on SOFC cathodes,” *Solid State Ionics*, vol. 148, no. 1–2, pp. 1–14, 2002.
- [18] S. Zha, Y. Zhang, and M. Liu, “Functionally graded cathodes fabricated by sol-gel/slurry coating for honeycomb SOFCs,” *Solid State Ionics*, vol. 176, no. 1–2, pp. 25–31, 2005.
- [19] E. D. Wachsman, G. R. Ball, N. Jiang, and D. A. Stevenson, “Structural and defect studies in solid oxide electrolytes,” *Solid State Ionics*, vol. 52, no. 1–3, pp. 213–218, 1992.
- [20] J. Y. Park and E. D. Wachsman, “Stable and high conductivity ceria/bismuth oxide bilayer electrolytes for lower temperature solid oxide fuel cells,” *Ionics (Kiel)*, vol. 12, no. 1, pp. 15–20, 2006.
- [21] Y. J. Leng and S. H. Chan, “Anode-supported SOFCs with Y₂O₃-doped Bi₂O₃/Gd₂O₃-Doped CeO₂ composite electrolyte film,” *Electrochem. Solid-State Lett.*, vol. 9, no. 2, pp. 10–14, 2006.

Effect of various repetition coating and thickness of YSB electrolyte on the electrochemical performance of the single button cell solid oxide fuel cell

Dr. Dedikarni Panuh

Dody Yulianto, ST., MT

Dr. Muhammad Fadlullah Abd. Shukur

Department of Mechanical Engineering, Faculty of Engineering,
Universitas Islam Riau, Indonesia

Fundamental and Applied Sciences Department Universiti
Teknologi Petronas, Seri Iskandar, Malaysia



Outline

1. Introduction.
2. Objective.
3. Background.
4. Problem statements.
5. Hypothesis.
6. Methodology.
7. Results.
8. Conclusions.

Introduction

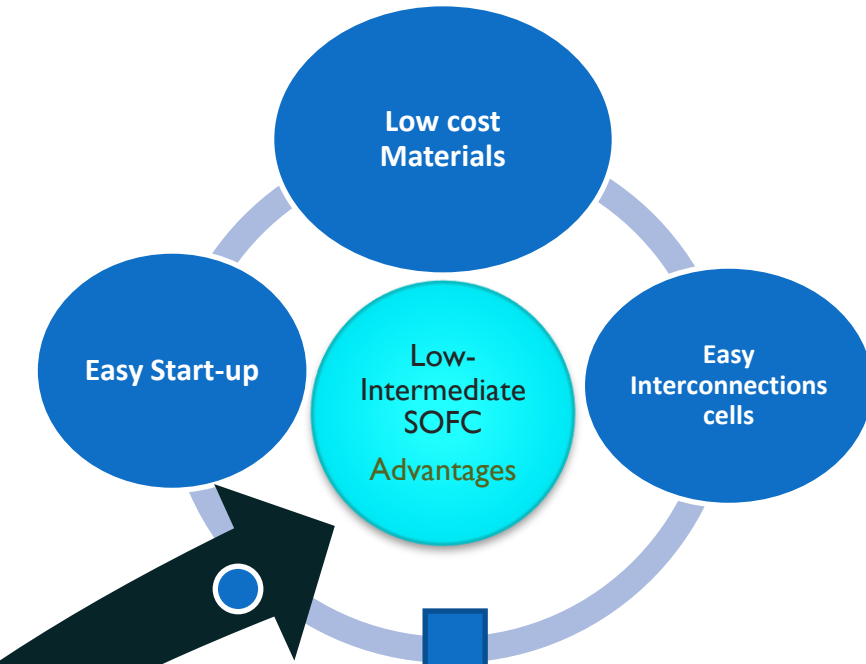
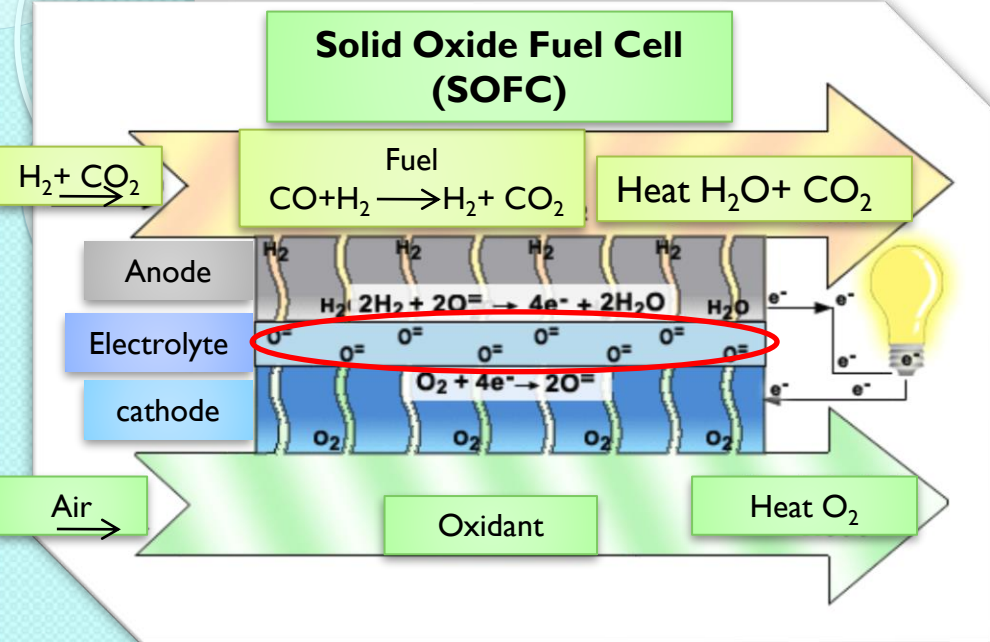

SOFC

High Temperature SOFC	Intermediate Temperature SOFC	Low Temperature SOFC
• 800-1000°C	• 600-800°C	• 400-600°C

Effect of decreasing temperature operations

Decreasing of electrolyte performance

Increasing of Interfacial Resistance

Increasing of Performance and Stability Electrolyte

Introduction

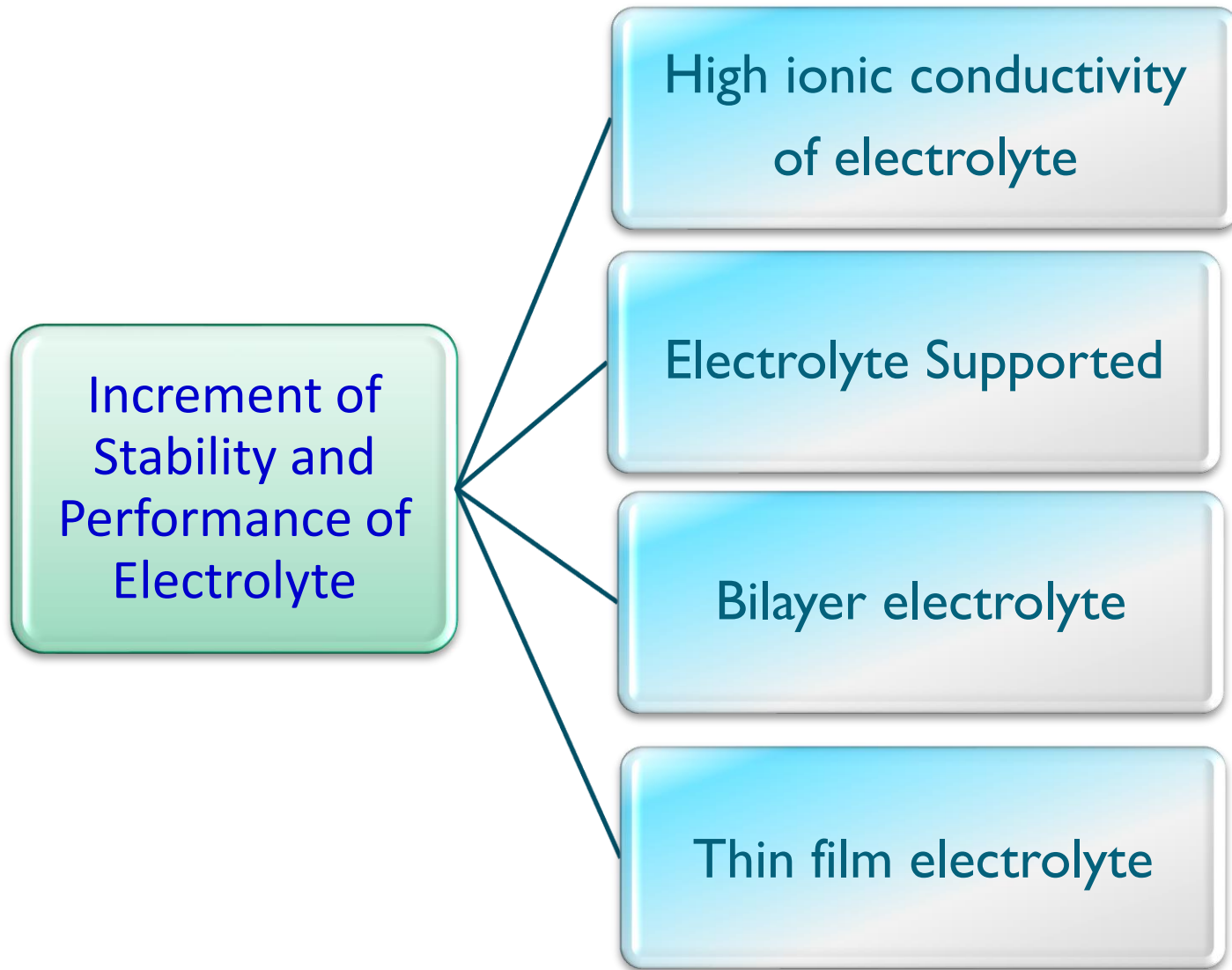

Problem statement

- ❑ Limited ionic conductivity materials for low- Intermediate Temperature SOFC
- ❑ Unstable ionic conductivity materials for low- Intermediate Temperature SOFC.
- ❑ Partial oxygen reaction reduction occurs at electrolyte

Hypothesis

- Using ionic conductivity materials based on Cerium and Bismuth at low temperature electrolyte
- Using stability material (doped) at low-intermediate temperature electrolyte.
- Using backing layer electrolyte as supported electrolyte and bilayered electrolyte to block electronic conduction from anode to cathode

OBJECTIVE

1. Synthesis of SDC and YSB electrolyte, NiO–SDC anode and Ag_2O_3 /YSB cathode powder.
2. Characterisation of SDC electrolyte on the anode substrate (ex. Effect of sintering to electrolyte, anode, cathode and interconnect).
3. Characterisation of coating times and operation temperature at (500°C , 550°C , 600°C and 650°C) to determine of open circuit performance, (OCV), current, and power density of single cell.
4. Characterisation of thin bilayer electrolyte YSB to determine of electrochemical performance of single cell.

Flow chart of manufacturing of single button cell system

NiO-SDC | SDC | YSB | Ag₂O₃-YSB

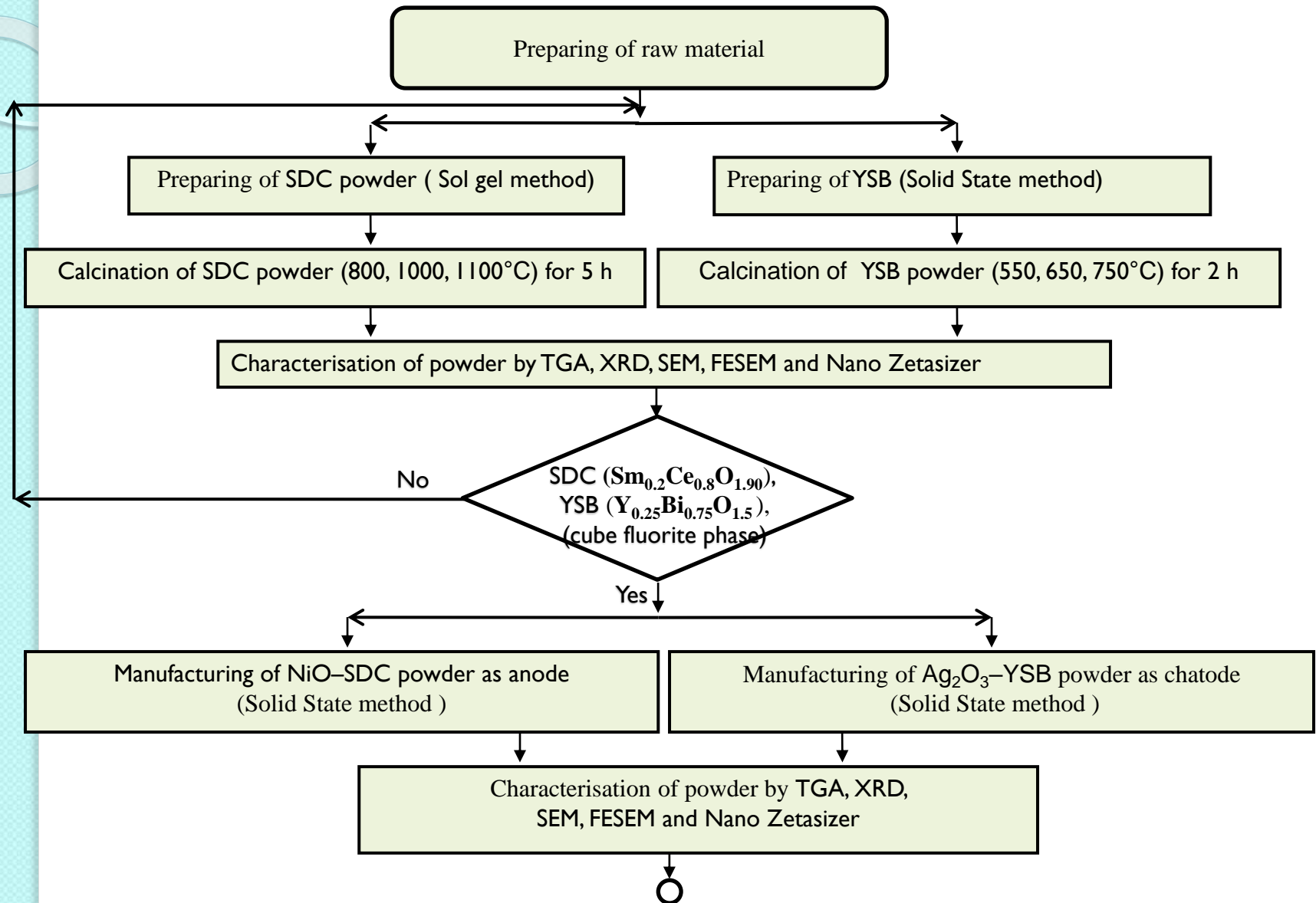

Flow chart of manufacturing of single button cell system NiO-SDC | SDC | YSB | Ag₂O₃-YSB

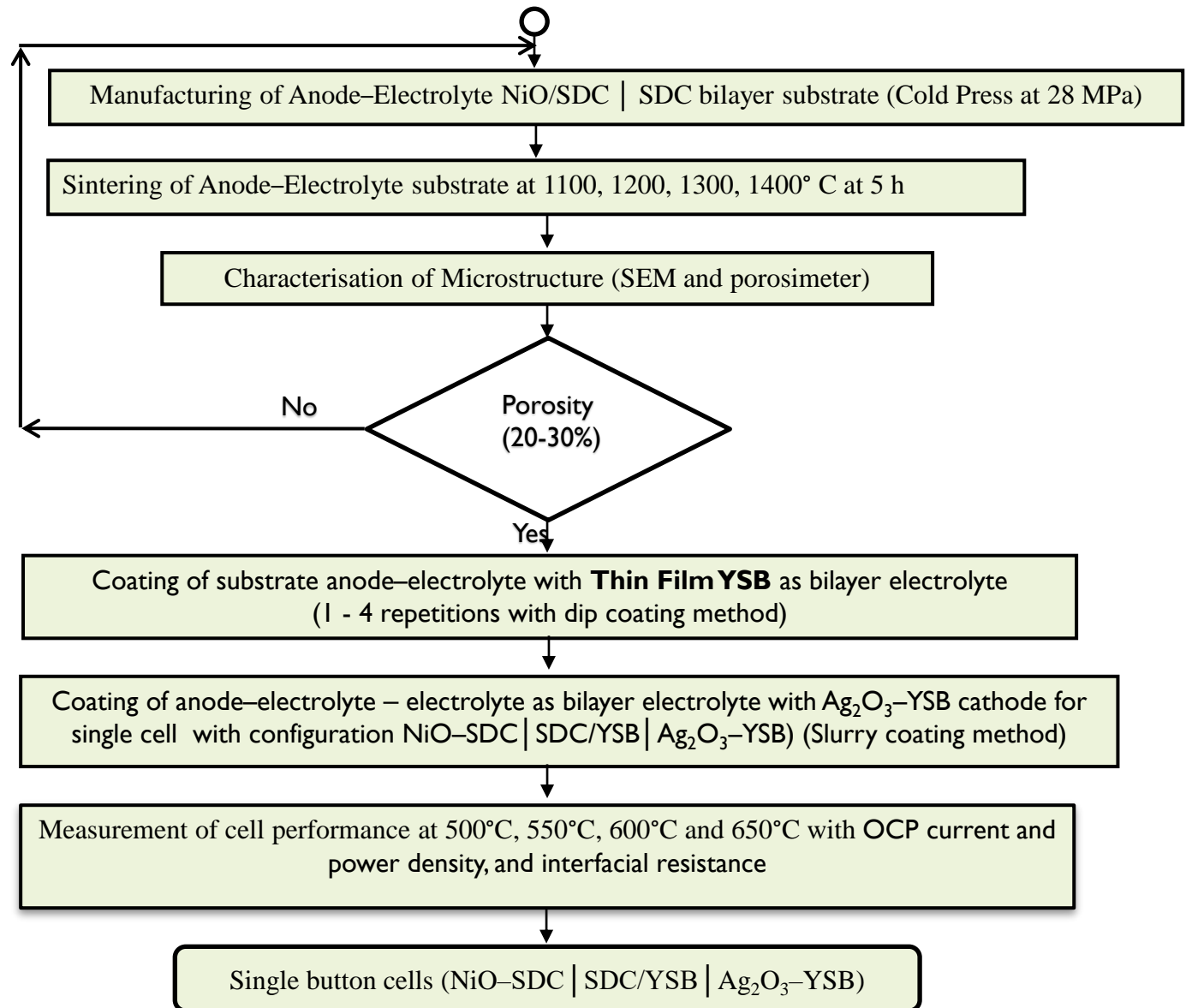

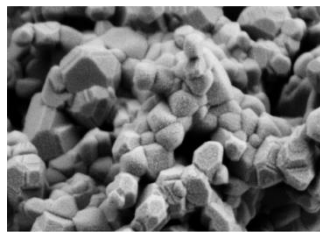

NiO/SDC powder

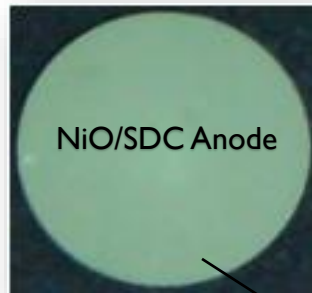

NiO/SDC Anode

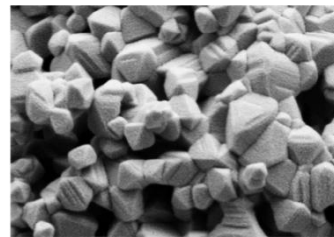

SDC powder

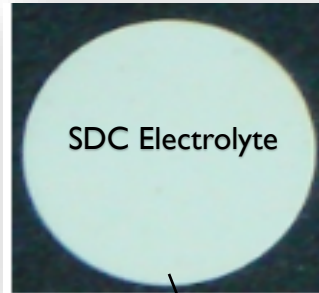

SDC Electrolyte

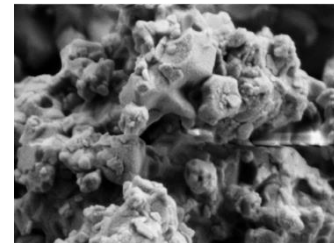

YSB powder

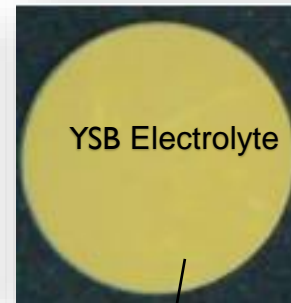

YSB Electrolyte

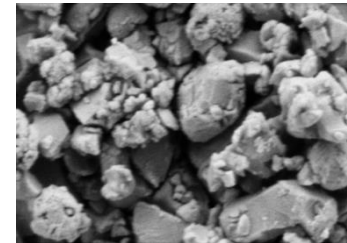

Ag₂O₃/YSB powder

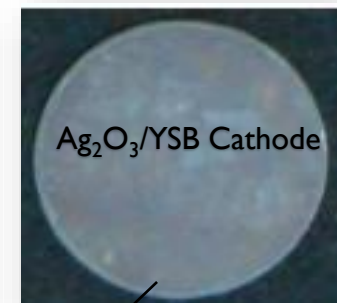

Ag₂O₃/YSB Cathode

Bilayer electrolyte
(SDC/YSB)

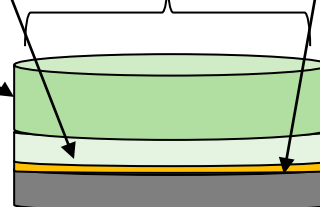

Button cell SOFC (NiO-SDC | SDC/YSB | Ag₂O₃-YSB)



Result

X-Ray Diffraction Analysis

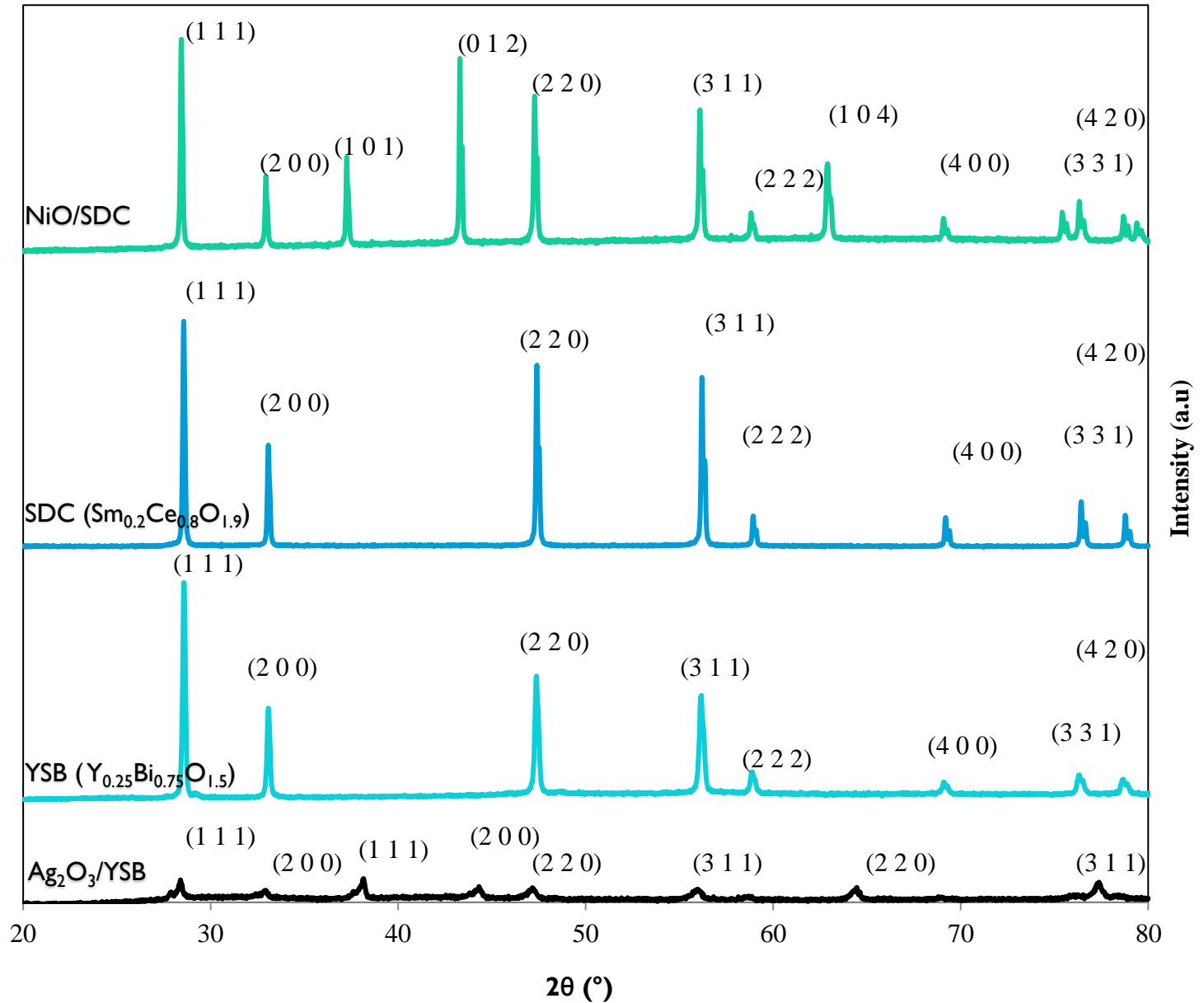

Thermogravimetric analysis (TGA)

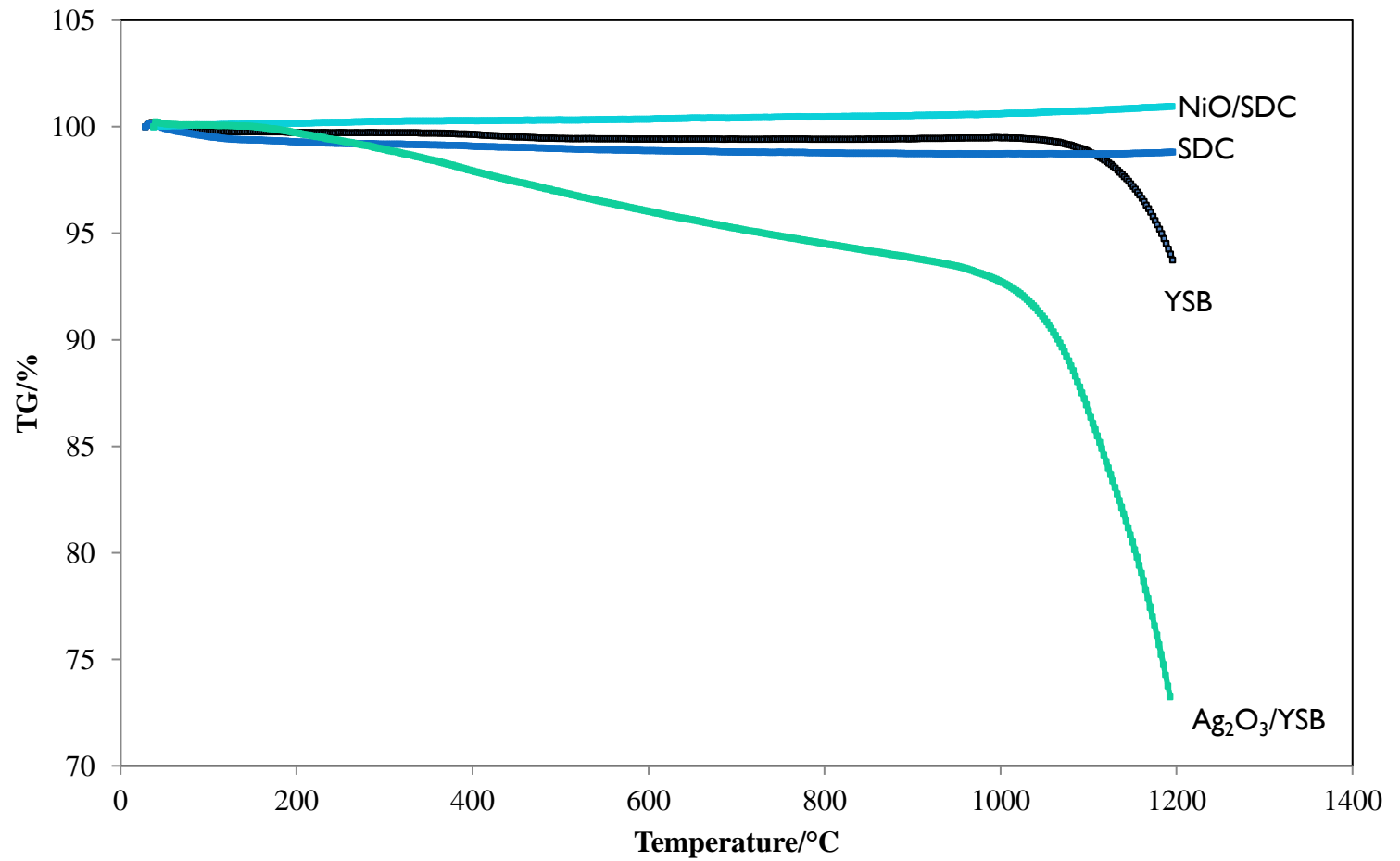

Micrographs of average particle size distributions (a) SDC, (b) YSB, (c) NiO-SDC and (d) Ag₂O₃-YSB with magnification 50000x with SEM and Zetasizer Nano

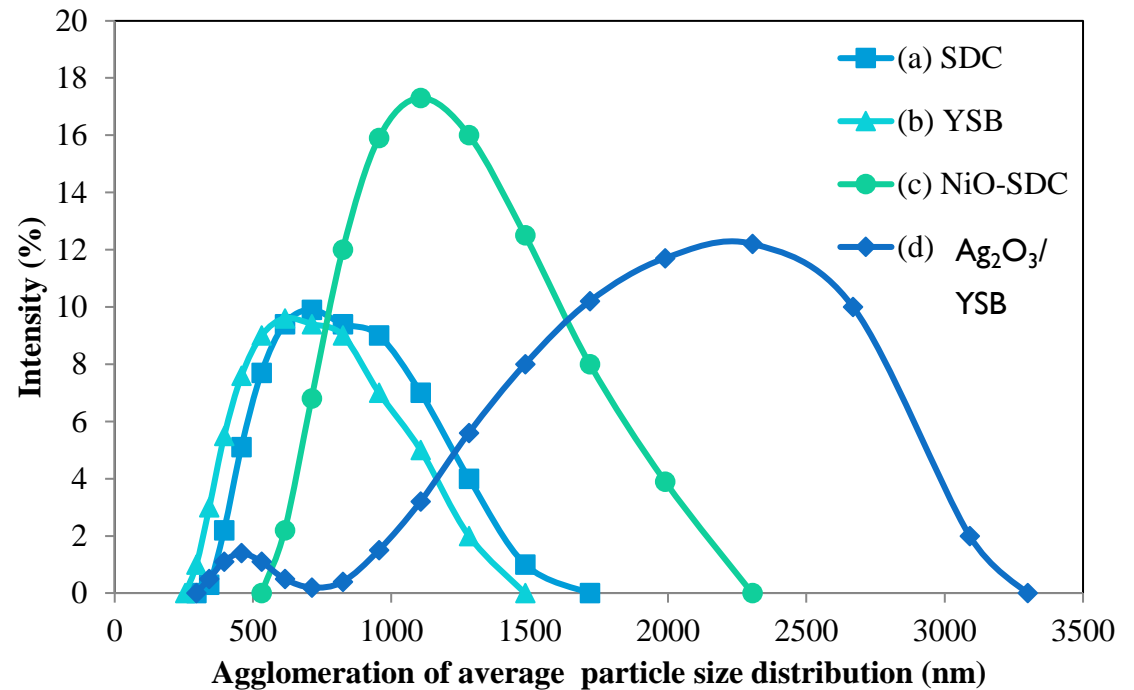
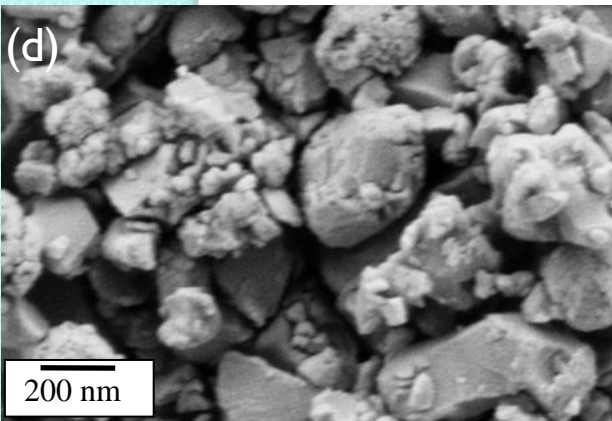
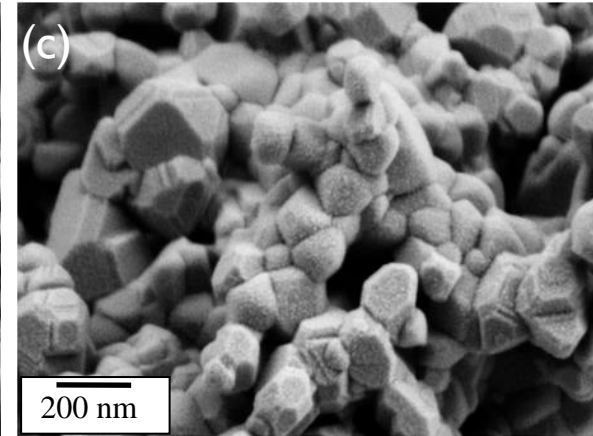
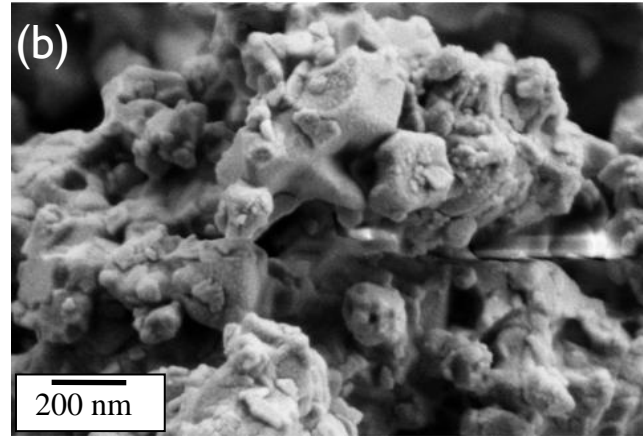
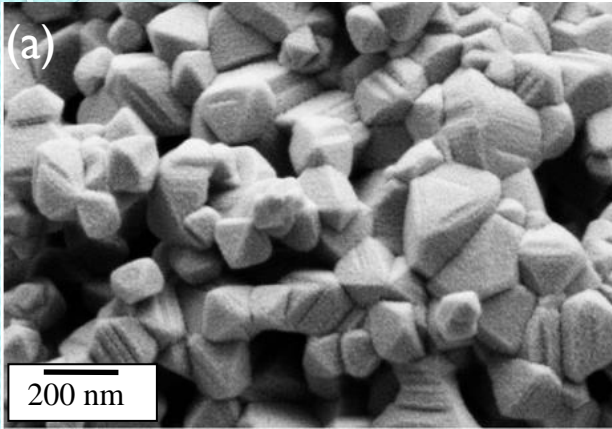

Effect of sintering temperature to electrolyte and anode microstructure at (a) 1100, (b) 1200, (c) 1300, (d) 1400, (e) 1500 °C for 5 h

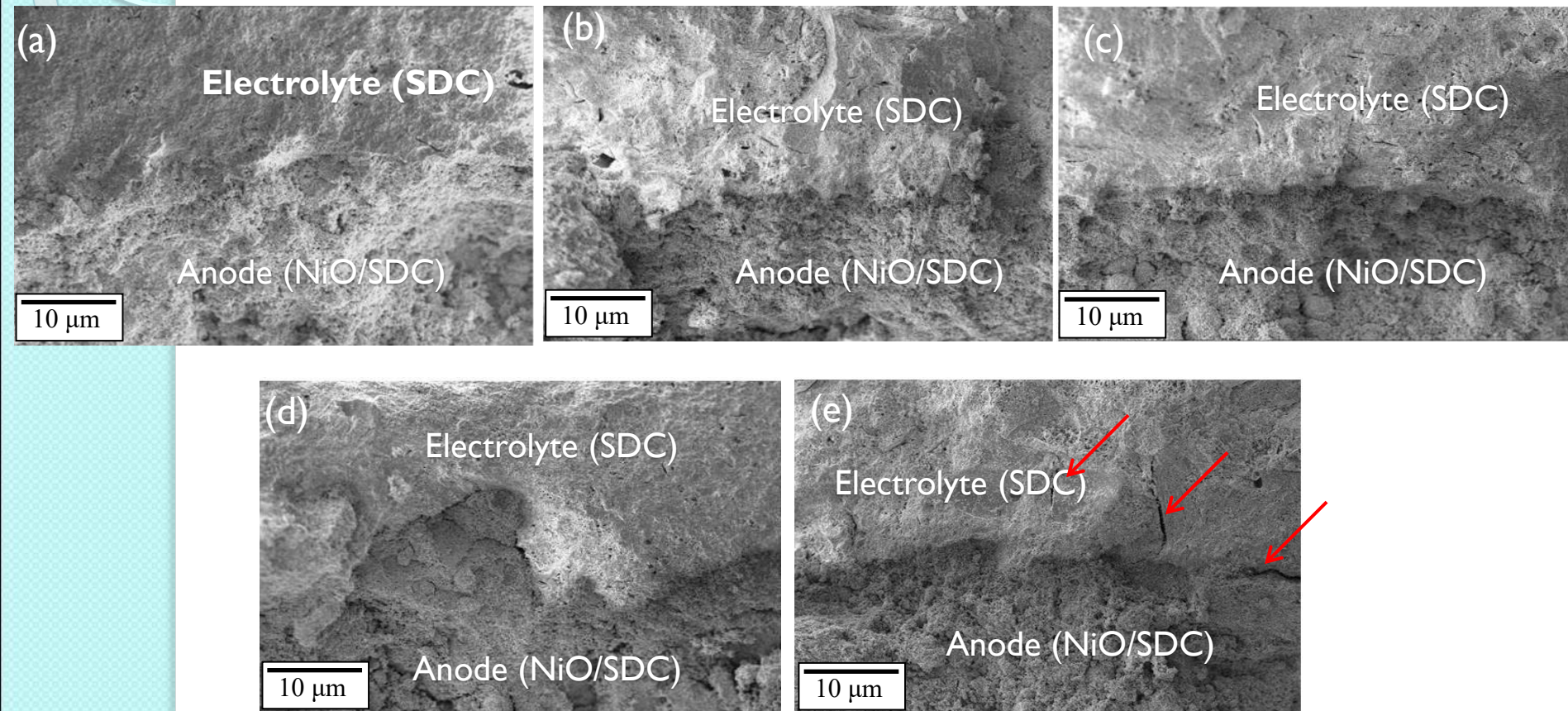

Effect of sintering temperature on anode-electrolyte substrate to performance cell at operation temperatures

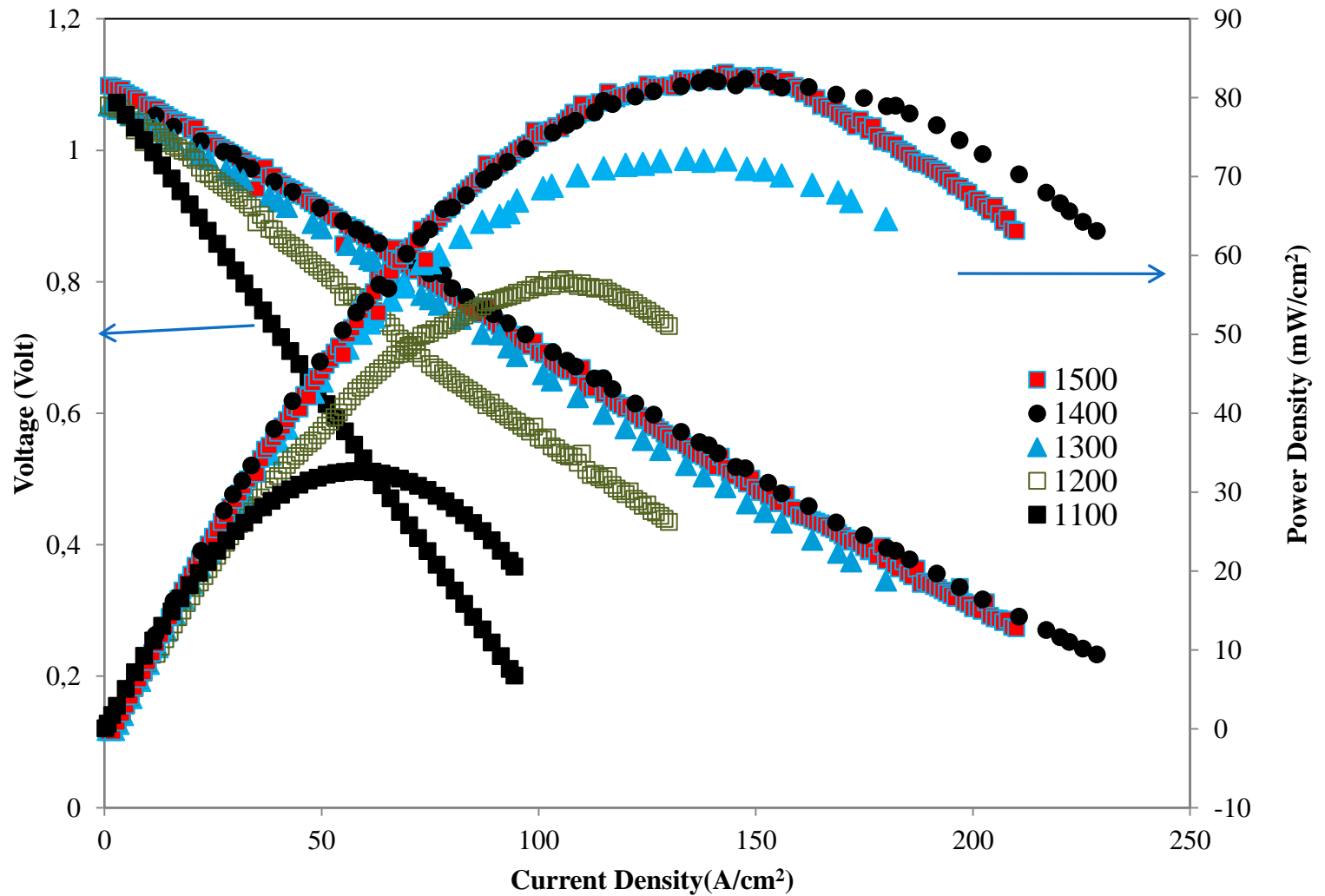

Grain boundary SDC Electrolyte micrograph after sintering at temperature: (a) 1100 ,(b) 1200, (c) 1300, (d) 1400 °C at 5 h with 50000x magnification

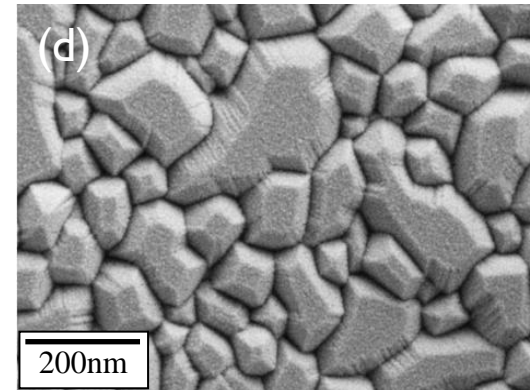
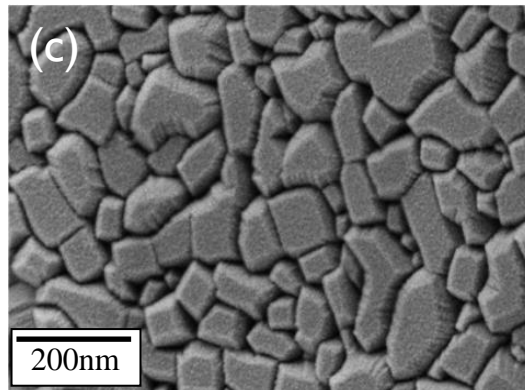
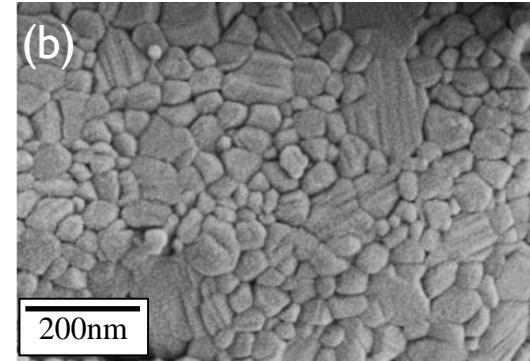
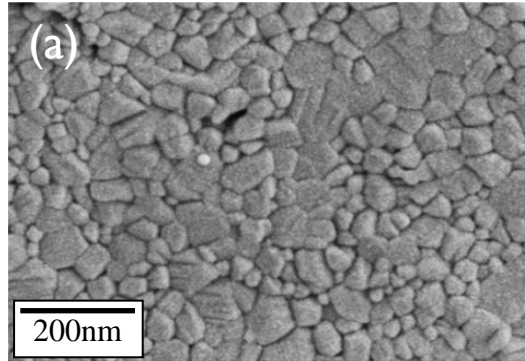

Current and voltage performance of (1.5 - 7.5 μm) thickness electrolyte on the thin film (YSB) electrolyte with SDC substrate

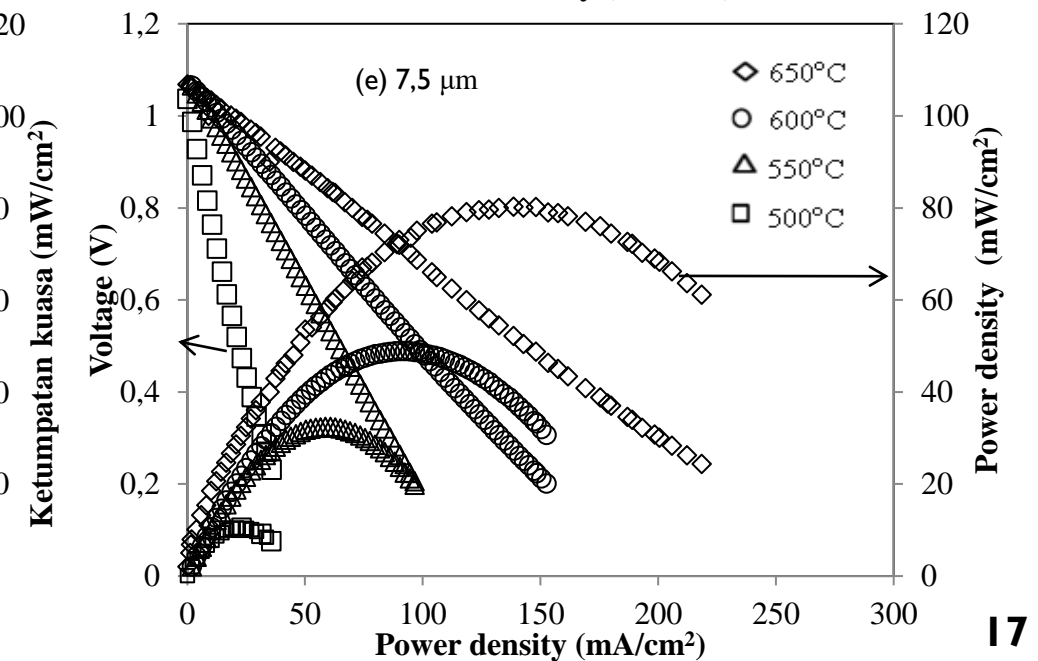
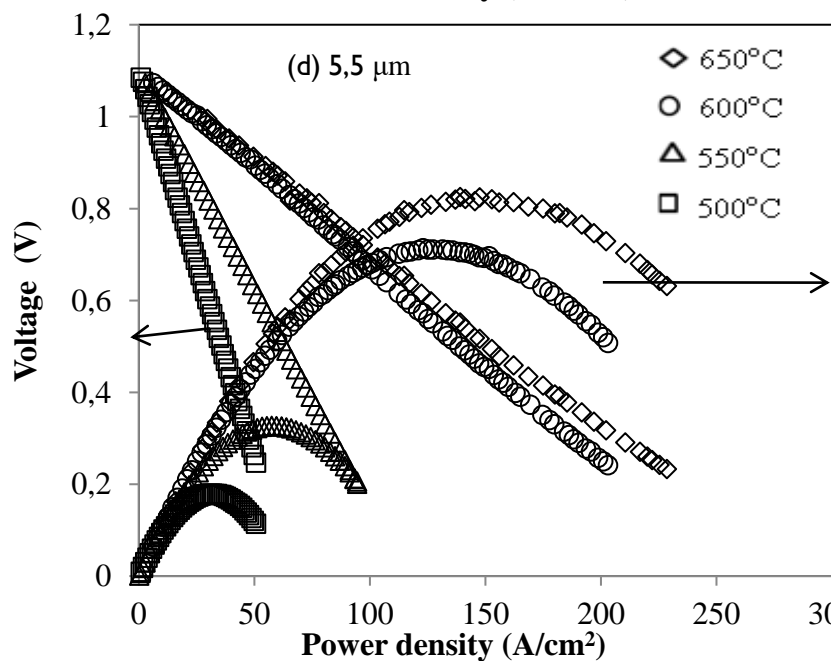
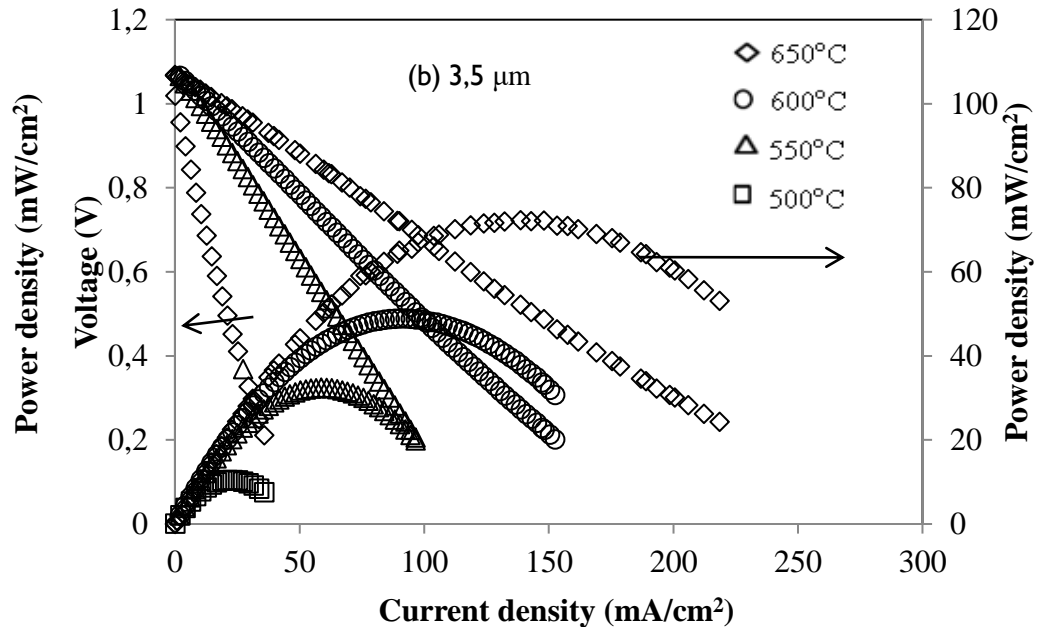
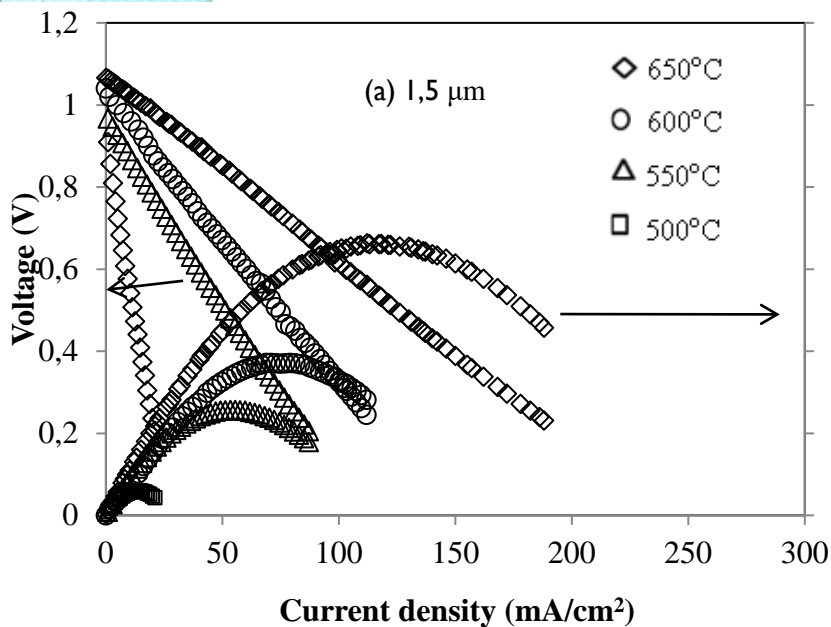

Effect of coating times process to current density and power density single cell

Repetition coating process and thickness YSB electrolyte

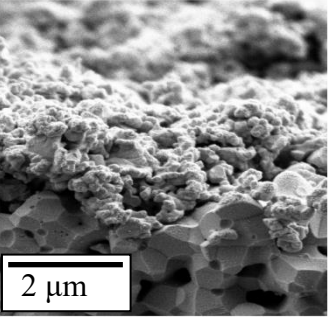
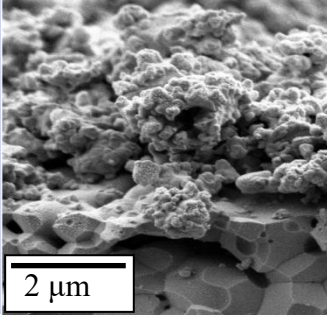
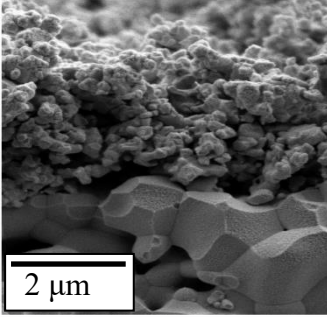
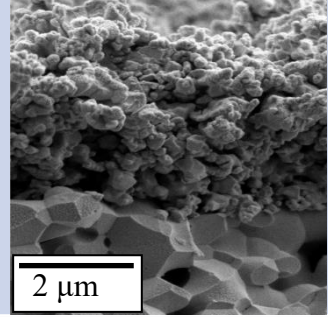
Coating (times)	1			2			3			4		
Thickness average	1.5 μm			3.5 μm			5.5 μm			7.5 μm		
												
Temp (°C)	OCP (Volt)	Power (mW/cm ²)	Current (mA/cm ²)	OCP (Volt)	Power (mW/cm ²)	Current (mA/cm ²)	OCP (Volt)	Power (mW/cm ²)	Current (mA/cm ²)	OCP (Volt)	Power (mW/cm ²)	Current (mA/cm ²)
500	1.068	5.9	19.1	1.072	11	33.7	1.092	18	46.7	1.084	10	31.3
550	1.068	25.60	84.9	1.072	32	94.5	1.092	33	89.2	1.084	32	95.6
600	1.068	37.1	111.9	1.072	49	147.3	1.092	71	195.7	1.084	49	148.3
650	1.068	66.1	188	1.072	72	212.2	1.092	82	225.3	1.084	80	218.7

Standard deviation <5% 18

Effect of thickness YSB electrolyte versus electrochemical performance (Impedance electrochemical impedance) of single cell

Effect of coating thickness YSB electrolyte to impedance spectrum : (a). 1.5, (b) 3.5, (c) 5.5 dan (d). 7.5 μm

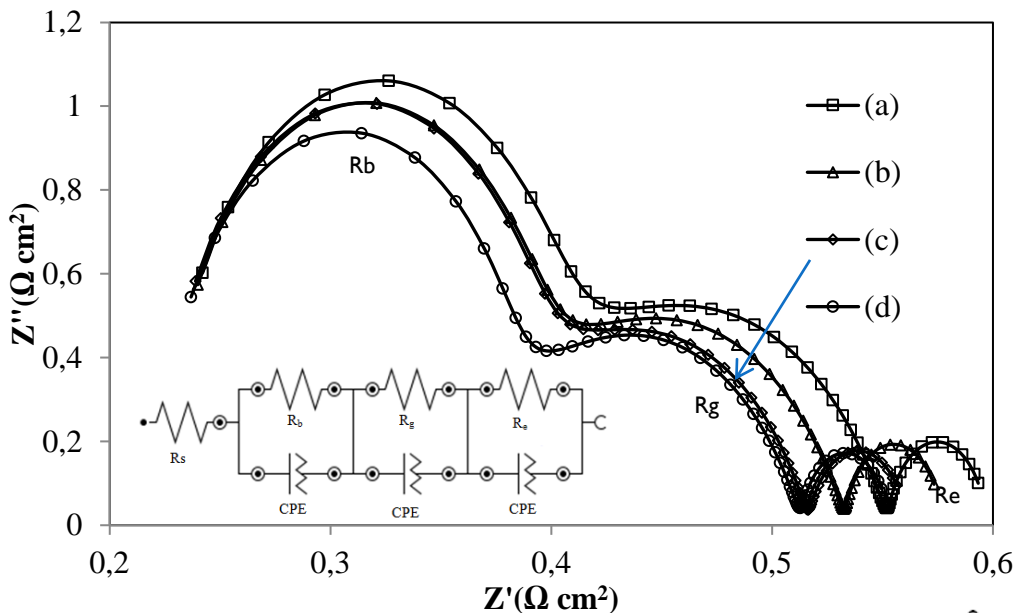

Effect of operation temperature YSB electrolyte to impedance spectrum : (a) 500°C, (b) 550°C, (c) 600°C and (d) 650°C

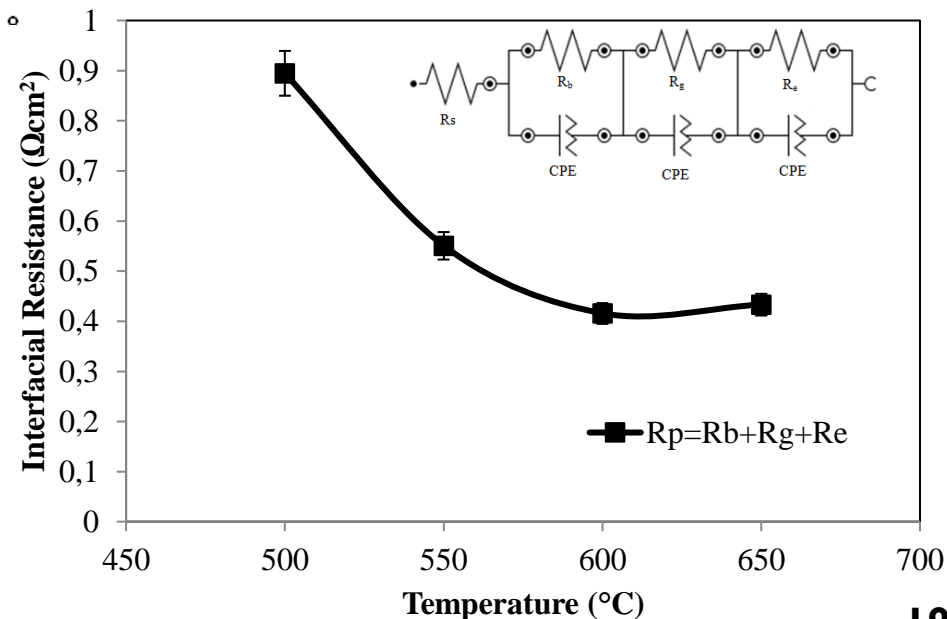
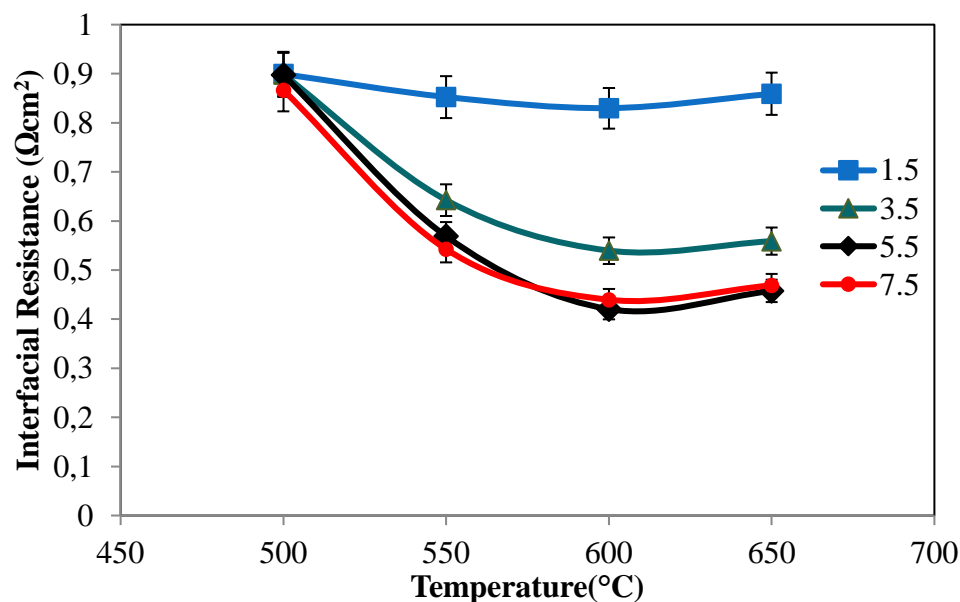
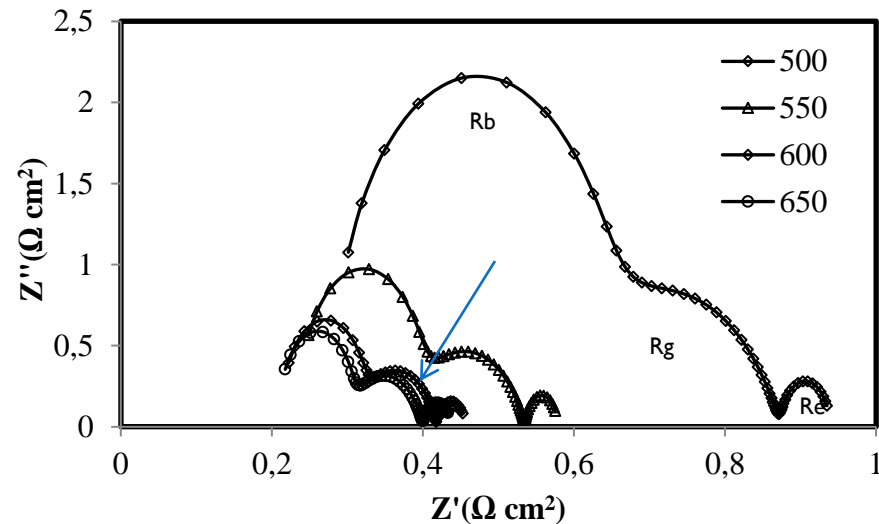

Result of interfacial polarization resistance versus previous research with difference temperature

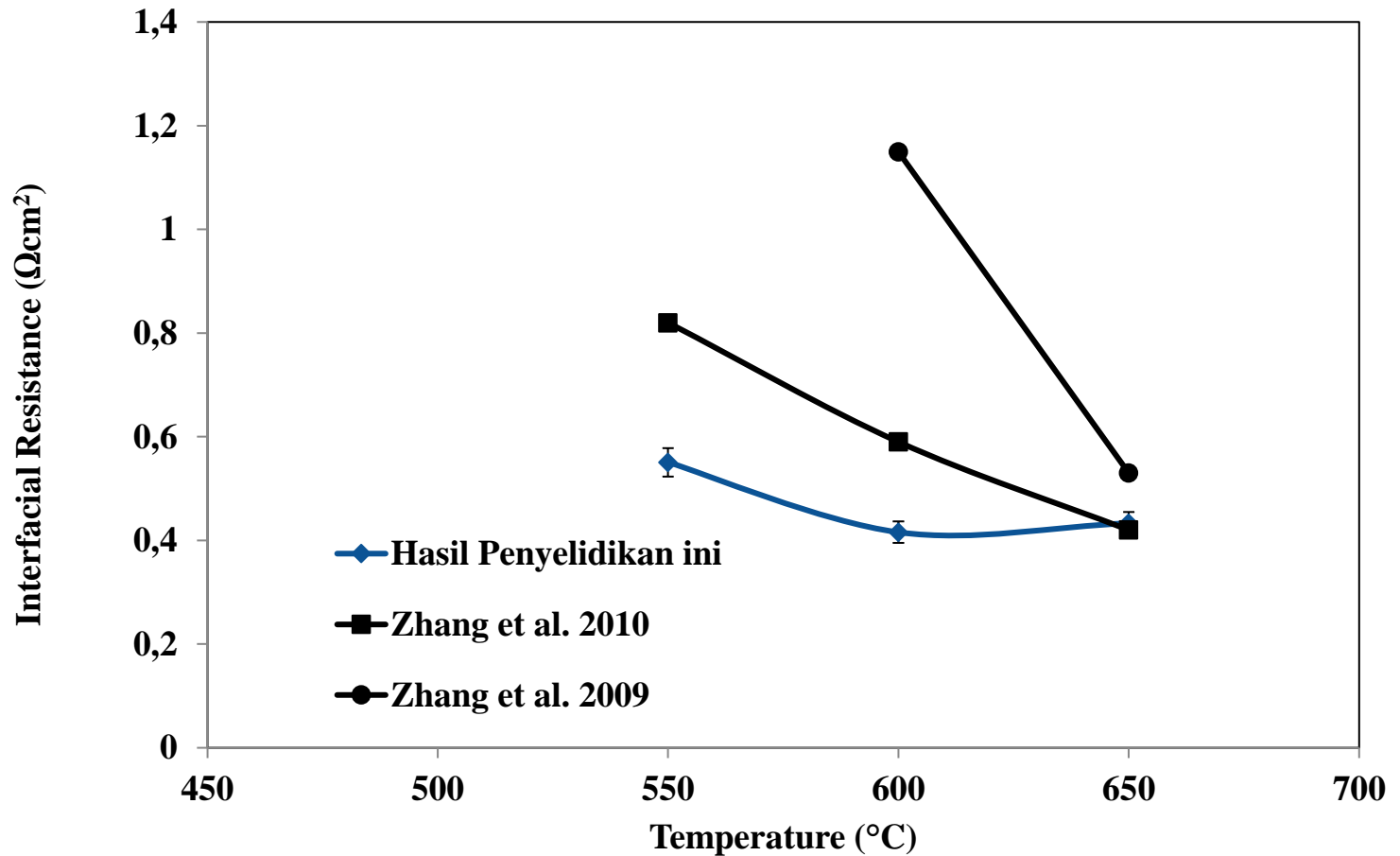

Effect of electrolyte thickness to OCP compared previous study

Anode	Electrolyte				Cathode	OCP(V)	Reference
	Layer 1	Thickness	Layer 2	Thickness			
NiO-SDC	SDC	0.5 mm	YSB	5.5 μm	Ag ₂ O ₃ -YSB	1.092	The result of this study
NiO-SDC	SDC	26 μm	YSB	6 μm	Ag ₂ O ₃ -YSB	0.887	Zhang et al. 2011
Ni-SDC	SDC	26 μm	YSB	6 μm	LSM-YSB	0.897	Zhang et al. 2010
Ni-GDC	GDC	84 μm	YSB	6 μm	Pt	0.885	Leng & Chan 2006
Pt	SDC	1.5 mm	ESB	22 μm	Ag-ESB	0.949	Park & Wachsman 2006
Pt	SDC	1.5 mm	ESB	9 μm	Au	0.783	Park & Wachsman 2006
Pt	YDC, SDC, GDC	0.9 mm	ESB	50-60 μm	Au	0.901-0.977	Wachsman et al. 1992

Conclusion

1. SDC ($\text{Sm}_{0.2}\text{Ce}_{0.8}\text{O}_{1.90}$) Electrolyte powder – sol-gel method and YSB ($\text{Y}_{0.25}\text{Bi}_{0.75}\text{O}_{1.5}$) powder, NiO–SDC and Ag_2O_3 –YSB – Solid state method.
2. YSB thin film electrolyte with 1.5 – 7.5 μm thickness produced by dip coating method.
3. Electrochemical performance with YSB – (5.5 μm) thin film at 600°C operation temperature was produced OCP – 1.092 V, maximum current and power density 82 mW/cm^2 and 225.3 mA/cm^2 , respectively
4. Effect of coating times YSB thin film electrolyte on the substrate SDC electrolyte successfully block electronic conductivity to cathode and increased OCP until 1.092 V and decreasing interfacial polarization resistance until 0.42 Ωcm^2 , higher than previous study is 0.887 V and 0.59 Ωcm^2 at 600°C operation temperature, respectively.



Thank you

Terima kasih